

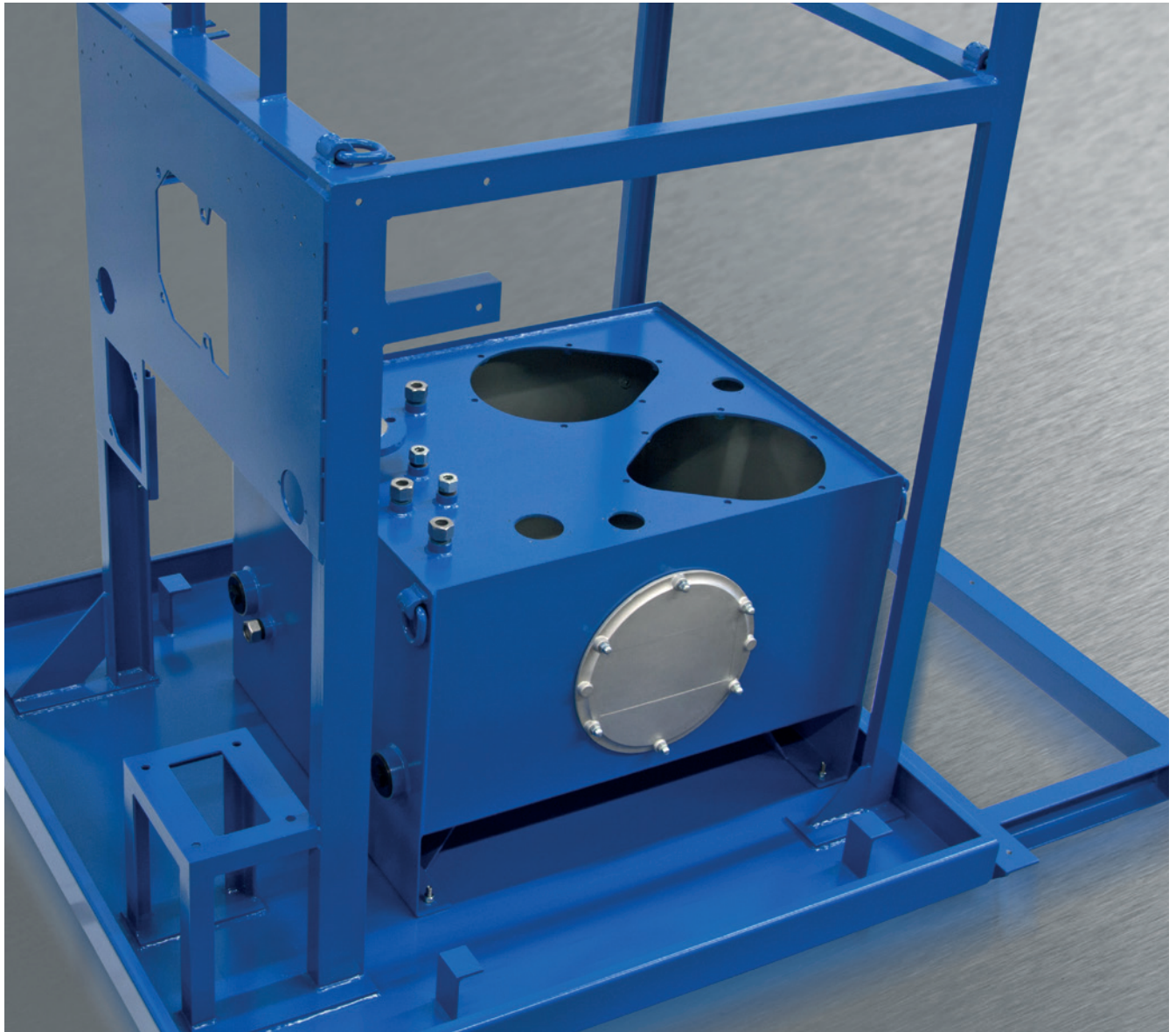

**OIL TANKS** **WELDED STEEL**

**OIL TANKS**  
**WELDED STEEL**

## OIL TANKS WELDED STEEL



### CONTENT

Service range	7
Product description / Order code	9
Series WN-LC / STB	10
Series according to DIN 24339	11
Lid dimensions	12
General dimensions	13
Oil sumps	14
General technical information	15

## OIL TANKS WELDED STEEL

### SERVICE RANGE

- Approved welding shop according to DIN 18800 - 7: 2002 - 09, class C
- Welding certificates available at [www.hbe-hydraulics.com](http://www.hbe-hydraulics.com)
- Approved shop according to § 19 I, WHG (Federal Water Act)
- Leak test with certificate on request
- Welding constructions and welded blanks
- Machining of normal steel S235JR (St37) or stainless steel 1.4301 (V2A) resp. 1.4571 (V4A)
- Reliable delivery periods and high quality standard

### TANKS ACCORDING TO CUSTOMER SPECIFICATION

- Tanks ready for mounting, oil sumps and welding constructions according to customer specifications
- Up to 20,000 litres resp. 6.4 tons
- Welded blanks and sandblastings
- Material S235JR (St37)
- Stainless steel 1.4301 (V2A) resp. 1.4571 (V4A), glass bead blasted inside and outside

Tanks according to customer drawing up to 20,000 litres resp. 6.4 tons

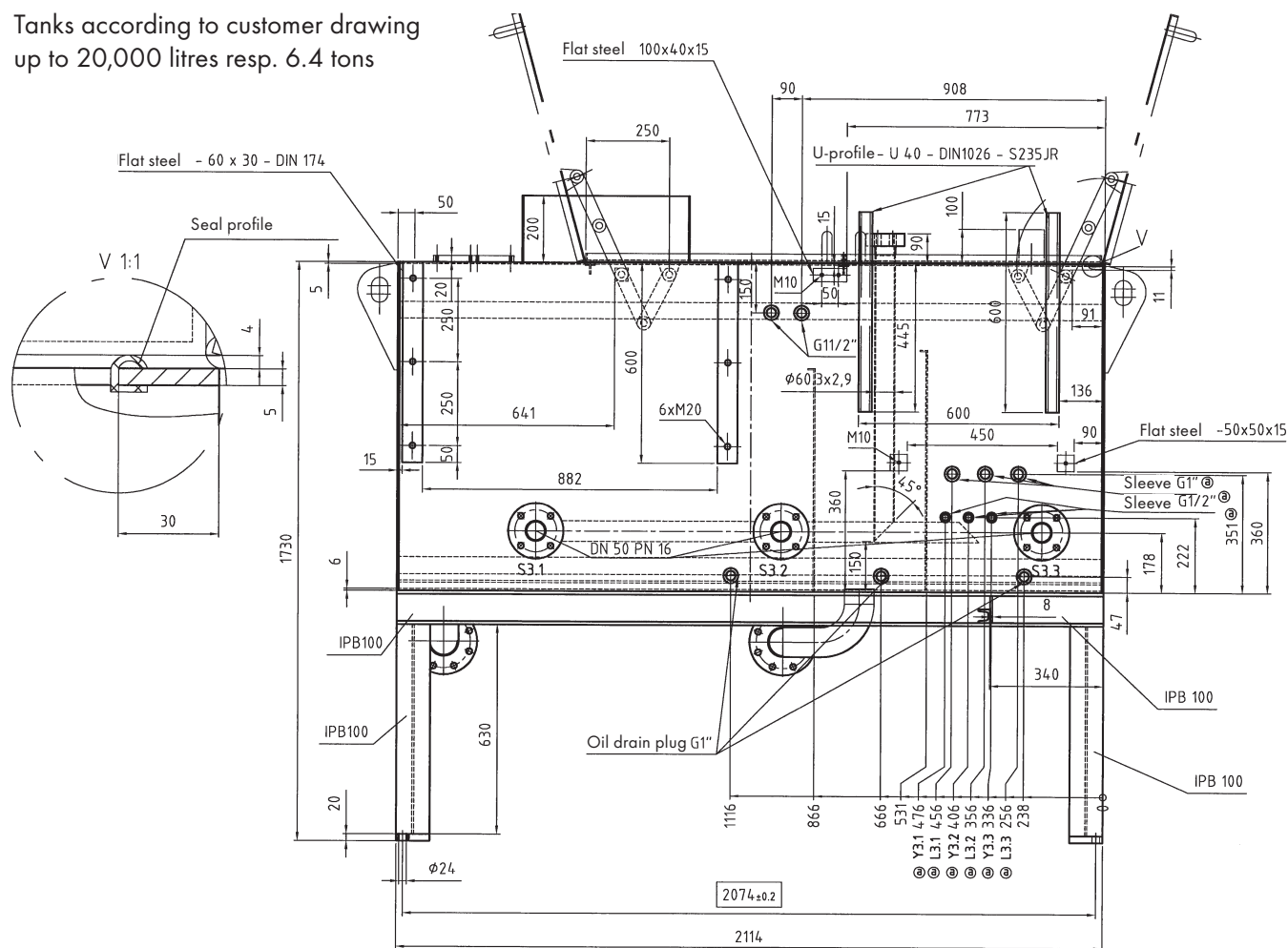

## OIL TANKS WELDED STEEL

### TANKS ACCORDING TO CUSTOMER SPECIFICATION



Special tank 250 L with cover  
S235 JR, powder-coated

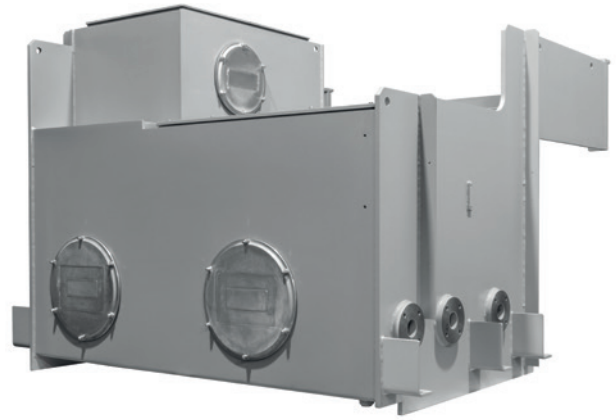

Special tank 2.300 L incl. additional tank  
S235 JR, primed

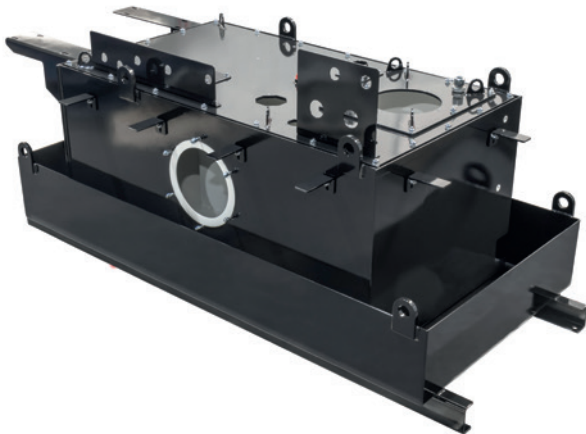

Special tank 500 L with oil sump  
S235 JR, painted



Special tank 2.500 L with base frame  
S235 JR, painted

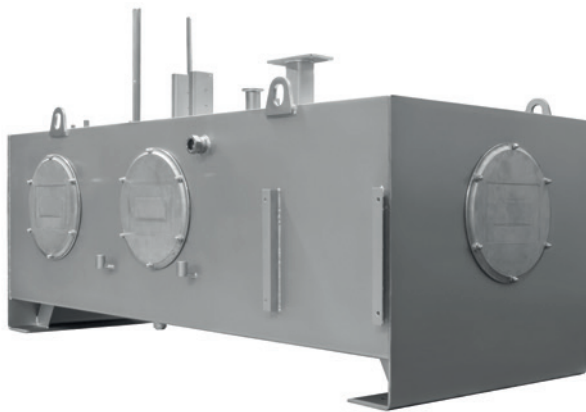

Special tank 2.200 L  
1.4571, glass bead blasted

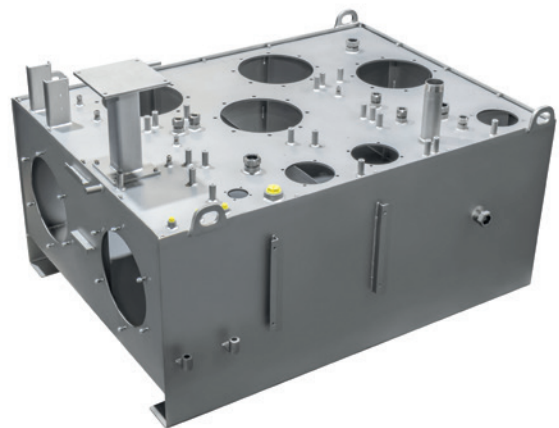

Special tank 1.400 L  
1.4301, glass bead blasted

## OIL TANKS WELDED STEEL

### PRODUCT DESCRIPTION

- Material S235JR (St37)
- Sandblasted and grounded inside and outside, resistant to hydraulic oil on mineral oil base
- Leak detection with dye penetrant test
- Gasket 15 x 5 mm made of perbunan (NBR) in case of screwed tank lid
- Drain plug DIN 908 + Cu gasket for oil drain at the tank



### AVAILABLE FOR EXTRA CHARGE

- Comprehensive range of HBE accessories, such as cleaning covers, gaskets, oil level gauges, fillers etc.
- Individual machining of lids
- Final varnish
- Primary coating resistant to special media (please see resistance table page 15)
- Stainless steel 1.4301 (V2A) resp. 1.4571 (V4A), glass bead blasted inside and outside
- Tightness certificate

#### Order code series WN-LC

Series	Size	Special lid machining
WN-LC	200	1020

#### Order code series STB

Series	Size	No. of cleaning openings	Fixing of filler	Fixing of level gauge
STB	630	2 RÖ	EF	ÖS
		0 RÖ		
		1 RÖ		
		2 RÖ		

#### Order code series DIN

Form	Size	Lid form	Fixing of filler	Fixing of level gauge	Version
A	1000	E	EF	ÖS	DIN 24339
A		A			
B		C			
		E			

## SERIES WN-LC / STB NG 40 – 2000 L

### DIMENSIONS

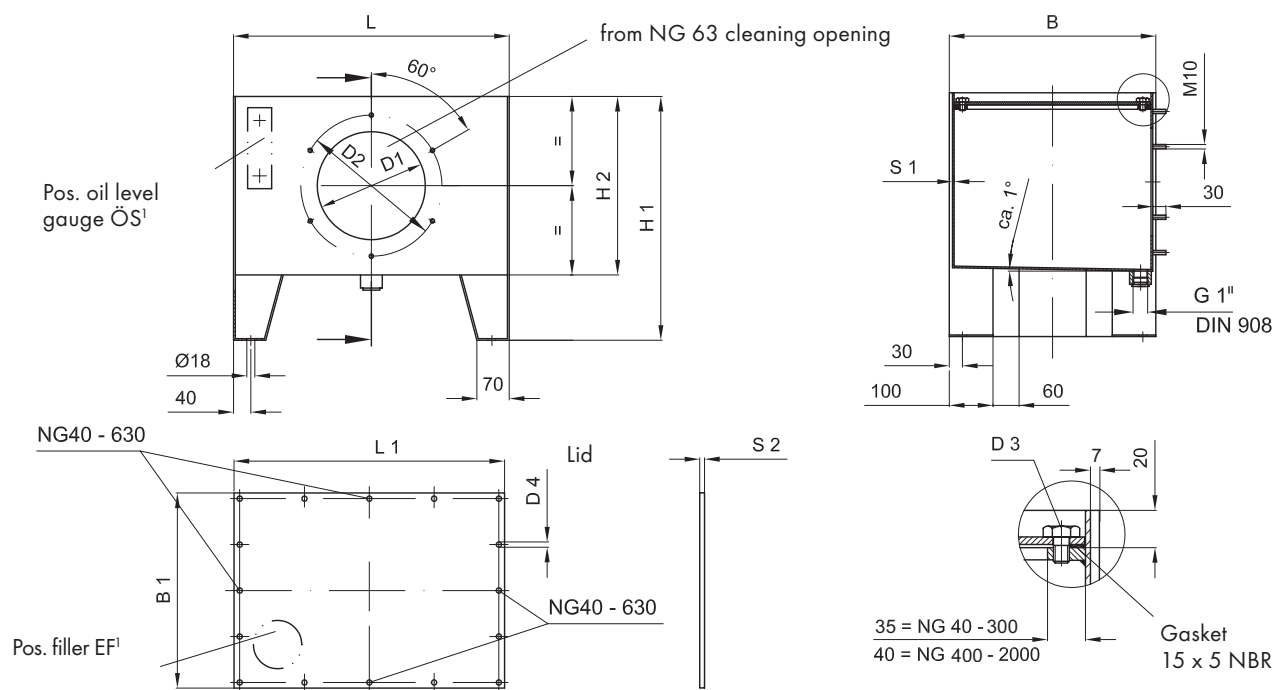

<sup>1</sup>Standard for sizes 40 – 1,000 liters

	Nominal size [Ltr.]	Tank dimensions [mm]							No of cleaning covers <b>z</b>	Total weight [kg]	
		L	B	H1	H2	D1	D2	D3			S1
WN-LC	40*	508	379	430	280	-	-	M 10	4	-	40
	63*	508	379	560	410	248	324	M 10	4	1	53
	100*	633	474	560	410	248	324	M 10	4	1	60
	160*	810	604	560	410	248	324	M 10	4	1	85
	200*	900	654	560	410	248	324	M 10	4	1	98
	250*	1010	704	580	430	248	324	M 10	4	1	110
	300*	1150	714	580	430	248	324	M 10	4	1	150
	400*	1514	749	580	430	248	324	M 12	4	1	190
STB	630*	1514	959	770	520	383	449	M 12	4	2	285
	800*	2014	914	770	520	383	449	M 12	5	2	350
	1000*	2014	1079	800	550	383	449	M 12	5	2	420
	1250	2014	1349	800	550	383	449	M 12	5	2	540
	1600	2014	1444	900	650	383	449	M 12	6	2	660
	2000	2310	1564	900	650	383	449	M 12	6	2	800

\*available at short notice

**SERIES DIN 24339**  
**NG 63 – 2000 L**

**DIMENSIONS**

**Form A**

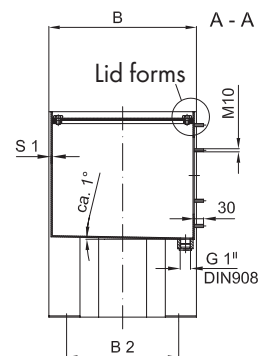
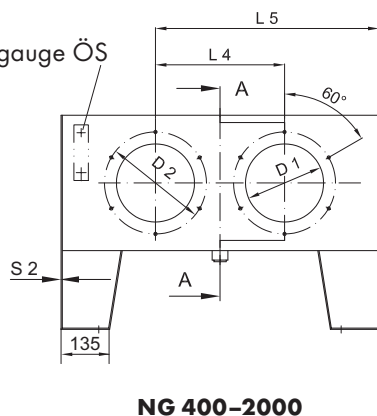
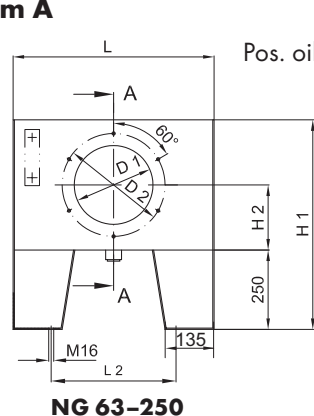

**Form B (with sump)**

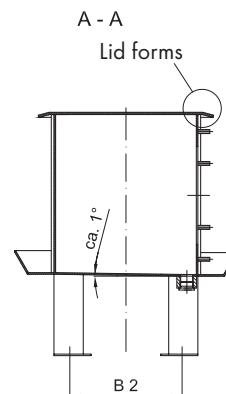
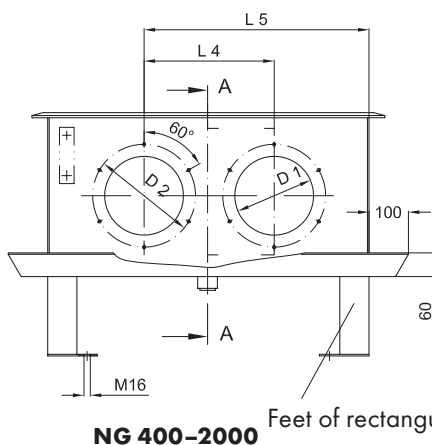
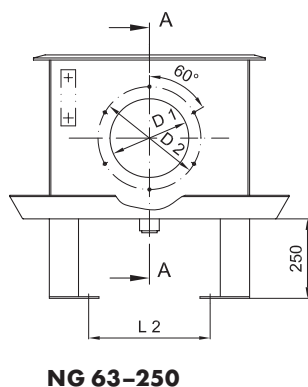

Nominal size [Ltr.]	Net capacity [Ltr.]	Tank dimensions [mm]													Total weight [kg]
		L	L2	L4	L5	B	B2	H1	H2	D1	D2	S1	S2	*	
63	57	508	308	-	-	379	285	660	205	248	324	4	4	1	55
100	91	633	393	-	-	474	360	660	205	248	324	4	4	1	65
160	150	810	570	-	-	604	490	660	205	248	324	4	4	1	90
250	232	1010	770	-	-	704	590	680	215	248	324	4	4	1	115
400	367	1514	1274	750	1130	749	635	680	215	248	324	4	6	2	200
630	597	1514	1274	750	1130	959	845	770	265	383	449	4	6	2	300
800	756	2014	1774	1000	1505	914	800	770	265	383	449	5	6	2	360
1000	959	2014	1774	1000	1505	1079	965	800	285	383	449	5	6	2	440
1250	1200	2014	1774	1000	1505	1349	1235	800	285	383	449	5	6	2	550
1600	1574	2014	1774	1000	1505	1444	1330	900	325	383	449	6	8	2	670
2000	1960	2310	2070	1150	1730	1564	1450	900	325	383	449	6	8	2	825

\*Number and type of cleaning covers

## LID DIMENSIONS

### Lid forms

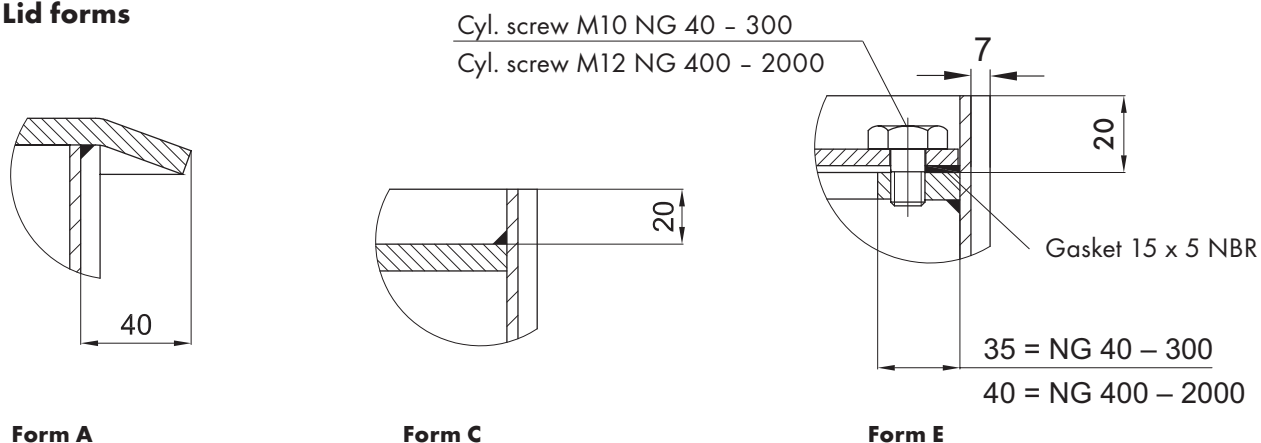

### NG 40 - 300

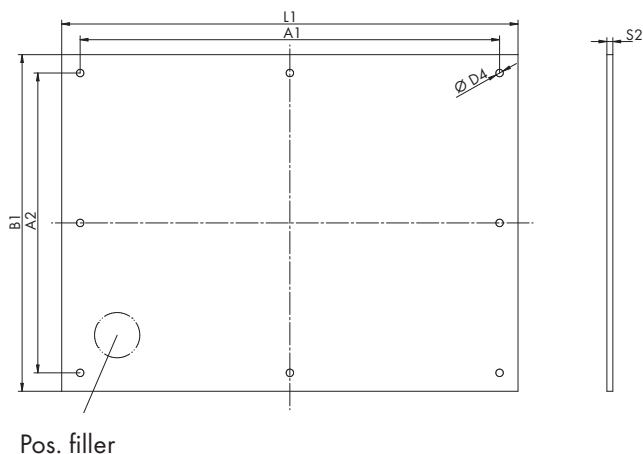

### NG 400 - 2000

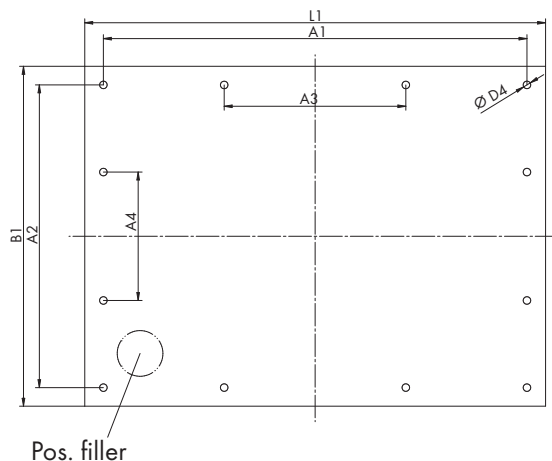

Nominal size [Ltr.]	Lid dimensions form E [mm]								Weight [kg]
	L1	B1	A1	A2	A3	A4	D4	S2	
40	490	347	448	305	-	-	12	6	8
63	490	347	448	305	-	-	12	6	8
100	615	442	571	398	-	-	12	6	13
160	792	572	748	528	-	-	12	6	22
200	882	622	838	578	-	-	12	6	26
250	992	672	948	628	-	-	12	8	42
300	1138	688	1112	662	-	-	12	8	49
400	1492	717	1440	667	480	222	14	8	67
630	1492	927	1440	877	480	292	14	10	108
800	1992	880	1940	830	647	277	14	10	137
1000	1992	1045	1940	995	647	332	14	10	163
1250	1992	1315	1940	1265	647	422	14	10	204
1600	1988	1408	1940	1358	647	478	14	10	219
2000	2284	1528	2240	1478	1120	558	14	10	273



# GENERAL DIMENSIONS NG 40 – 2000 L

## DIMENSIONS

Ös

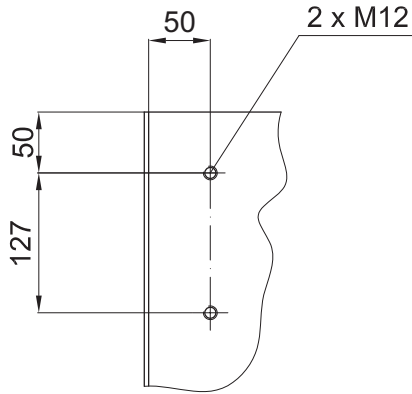

Bore for oil level gauge (standard)  
ÖS 127 = NG 40 - 400  
ÖS 254 = NG 630 - 2000

EF 40 – 300 Ltr.

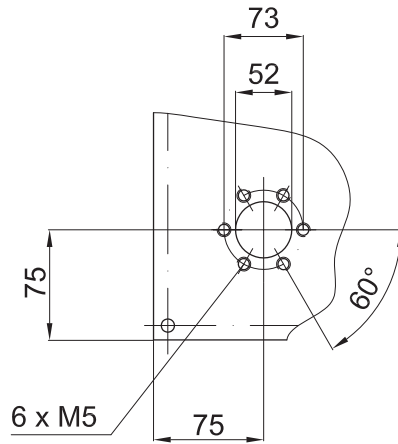

Filler bore (standard)

EF 400 – 2000 Ltr.

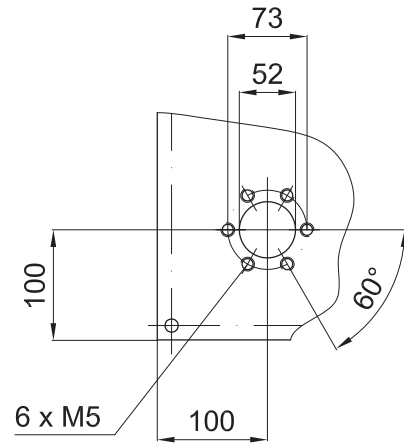

Filler bore (standard)

## EYE BOLTS

Version 1 (for NG 40 – 300)

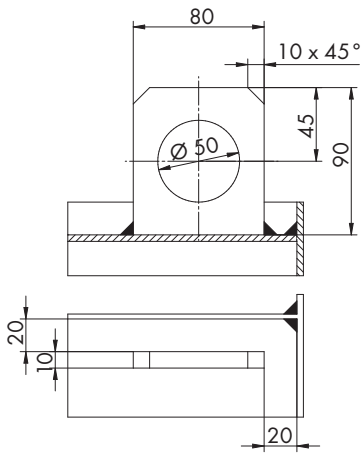

Version 2 (for NG 40 – 300)

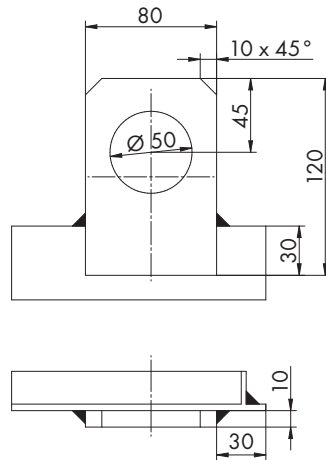

Version 3 (for NG 40 – 2000)

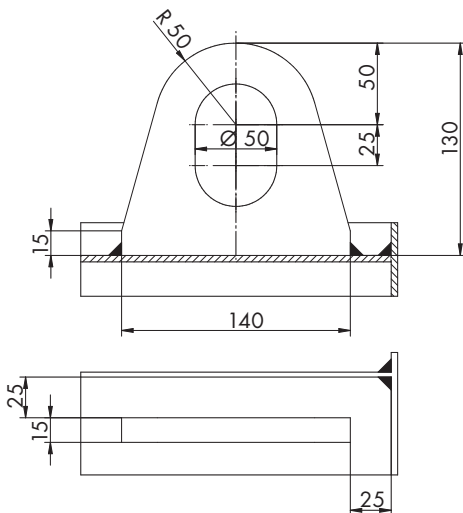

Version 4 (for NG 40 – 2000)

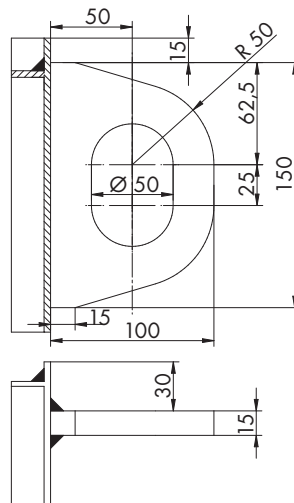

## OIL SUMPS NG 63 – NG 2000

### PRODUCT DESCRIPTION

- Storage volume corresponds to the net volume of the tank
- Version corresponds to the requirements WHG (Federal Water Act)
- General folded edge for protection against risk of injury
- Special sizes on request

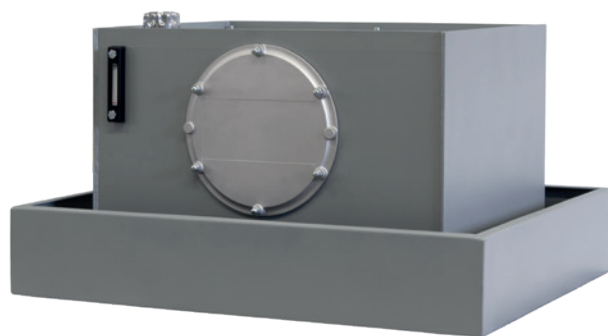

Order code						
Series		Size		Optional with feet		Tank series
ÖW	-	200	-	F	-	DIN

### DIMENSIONS

with feet

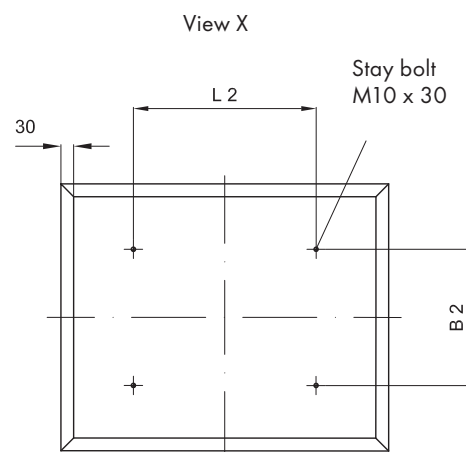
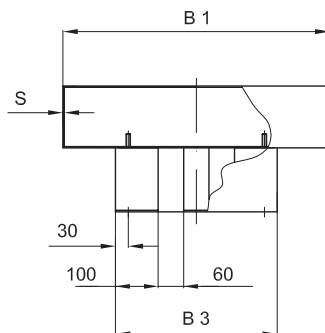
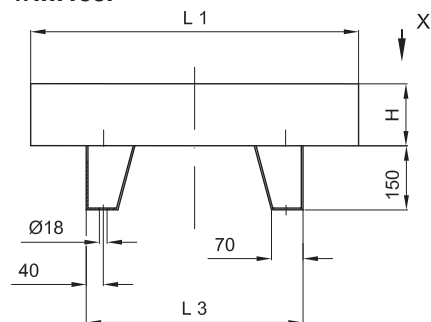

without feet

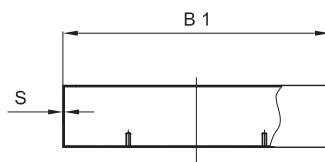
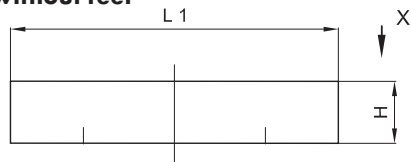

Nominal size [Ltr.]	Dimensions [mm]										Weight [kg]	
	L1	B1	H	L2		B2		Feet			with feet	without feet
				STB*	DIN	STB*	DIN	L3	B3	S		
ÖW 63	768	625	145	428	308	319	285	508	379	3	27	23
ÖW 100	893	720	170	553	393	414	360	633	474	3	36	31
ÖW 160	1070	850	190	730	570	544	490	810	604	3	48	41
ÖW 200	1160	900	200	820	-	594	-	900	654	3	53	47
ÖW 250	1270	950	220	930	770	644	590	1010	704	3	62	55
ÖW 300	1410	960	235	1070	-	654	-	1150	714	3	70	62
ÖW 400	1874	1095	220	1434	1274	689	635	1514	749	4	122	111
ÖW 630	1874	1305	260	1434	1274	899	845	1514	959	4	149	134
ÖW 800	2374	1260	270	1934	1774	854	800	2014	914	4	176	162
ÖW 1000	2374	1425	300	1934	1774	1019	965	2014	1079	4	200	184
ÖW 1250	2374	1695	330	1934	1774	1289	1235	2014	1349	4	240	220
ÖW 1600	2400	1900	380	1934	1774	1384	1330	2014	1444	4	275	255
ÖW 2000	2800	1900	400	2234	2070	1504	1450	2314	1564	4	317	294

\*also applies for series WN-LC

## GENERAL TECHNICAL INFORMATION

**TABLE OF RESISTANCE AGAINST MINERAL OILS  
AND FLAME RESISTANT FLUIDS**

Product	Material	Medium				
		Hydraulic oil / mineral oil base	HFA	HFB	HFC	HFD, HFD-R, HFD-S, HFD-T
Steel tanks	Steel	●	1	●	●	●
Coating	ME III	●	●	●	2	2
Gasket	NBR	●	●	●	●	●
Gasket	EPDM	●	●	●	●	●
AB tanks	Aluminium	●	●	●	●	●
Gasket	Paperboard	●	●	●	●	●
Gasket	Rubber cork	●	●	●	3	3
Lid SD	Steel	●	1	●	●	●
Oil level gauges						
with gasket	NBR	●	●	●	●	●
with gasket	FPM	●	●	●	●	●
Fillers	ST	●	●	●	●	●
Cleaning covers	Aluminium	●	●	●	●	●
with gasket	NBR	●	●	●	●	●
with gasket	FPM	●	●	●	●	●
with gasket	EPDM	●	●	●	●	●

● = Resistant

● = Not resistant

1 = Priming coat required

2 = If coating required, use epoxy resin

3 = Resistant to oil wetting

### HYDRAULIC FLUIDS / MAIN COMPONENTS

**HFA** Oil in water emulsion, water content > 80%

**HFB** Water in oil emulsion, water content > 40%

**HFC** Watery polymer solution (water glycol),  
water content > 45%

**HFD** Synthetic fluids (water free)

**HFD-R** Phosphoric acid ester

**HFD-S** Chlorinated hydrocarbon

**HFD-T** Mixture of HFD-R + HFD-S



Cutting system



Welding



Paint spray cabin



Paint spray cabin

Online catalogue



[epaper.hbe-hydraulics.com/en](http://epaper.hbe-hydraulics.com/en)

**HBE** hydraulic  
components

HBE GmbH  
Hönnestraße 47  
58809 Neuenrade /Germany

Phone +49 (0) 23 94 / 616-0  
Fax +49 (0) 23 94 / 616-25  
[info@hbe-hydraulics.com](mailto:info@hbe-hydraulics.com)  
[www.hbe-hydraulics.com](http://www.hbe-hydraulics.com)



**e.holding**  
FLUID TECHNOLOGY GROUP  
[www.e-holding.de](http://www.e-holding.de)

distributed by