

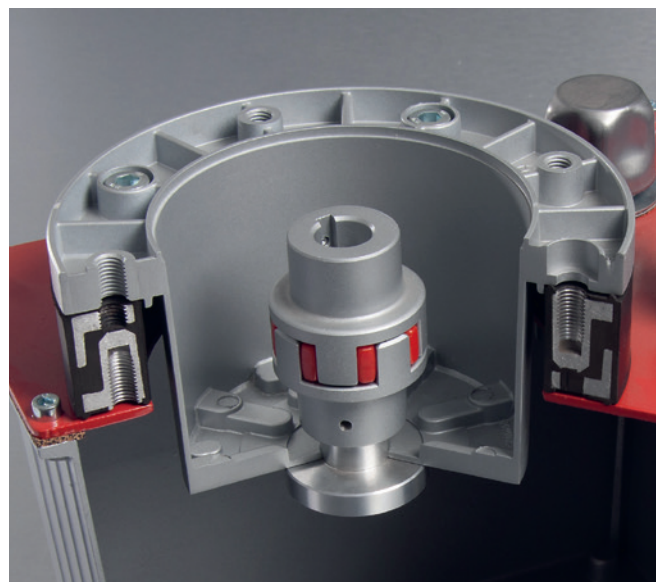

BELLHOUSINGS AND ACCESSORIES

BELLHOUSINGS AND ACCESSORIES

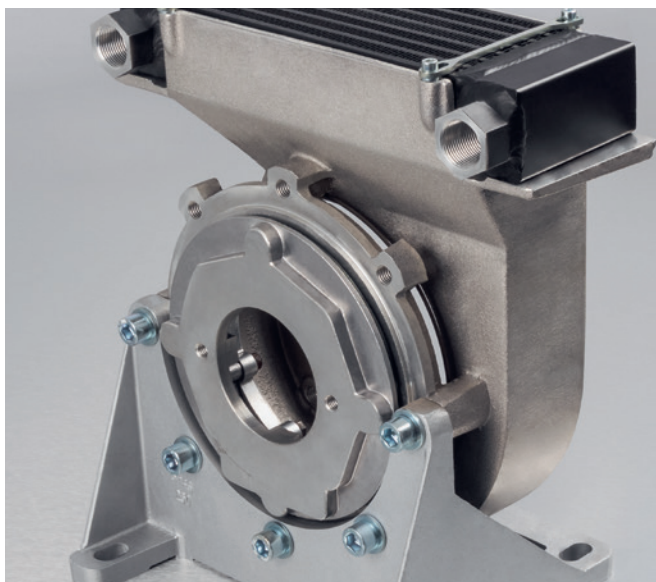
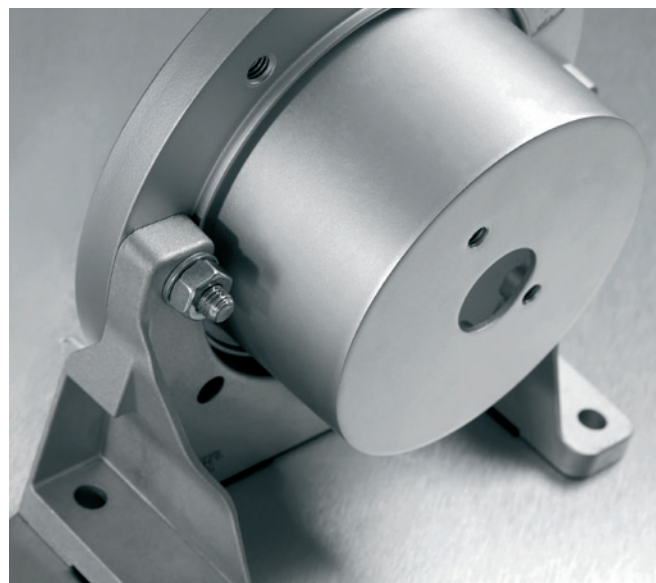

CONTENT

Rigid bellhousings	80
Damped bellhousings	82
Bellhousings for rectangular pump connections	84
Rectangular bellhousings with damping flange	88
Rectangular bellhousings for Honda motors	89
Bellhousings for NEMA motors	90
Cast iron bellhousings	92
Foot flanges	94
Damping elements	97
Mounting flanges	102
Gaskets for bellhousings	103
Bellhousings with oil cooler (PTÖK)	104

ROUND BELLHOUSINGS AND ACCESSORIES

PRODUCT DESCRIPTION

- Connection elements for centring between electric motor and hydraulic pump
- For all hydraulic pumps available at short notice
- Both mounting sides are finished
- Horizontal and vertical application possible
- Material: aluminium
- Other materials on request; please also see page 92

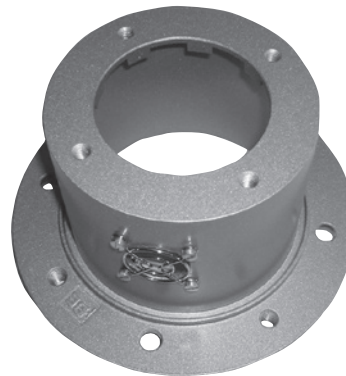

RIGID BELLHOUSINGS

ACC. TO VDMA 24561 FORM A

- Space saving storage due to stackability

Order code rigid bellhousings						
Type	Size		Length		Boring	
PR	250	/	124	/	433/1	

BELLHOUSINGS WITH DAMPING FLANGE

ACC. TO VDMA 24561 FORM B

- Reduction of noise level of the pump / motor unit up to 8 dB (A) possible, depending on pump construction
- Standard bellhousing made of aluminium, damping flanges made of aluminium / perbunan vulcanised
- No metallic connection
- Resistance: mineral oil max. 80°C



Order code bellhousings with damping flange						
Type	Size		Length		Size DF	Boring
PR	450	/	234	/	DF 300	...

BELLHOUSINGS FOR RECTANGULAR PUMP CONNECTIONS

- For all common external gear pumps
- Also available with damping flange, please see page 88



Order code bellhousings for rectangular pump connections						
Type	Size		Length		Boring	
PE (PRE)	250	/	115	/	20	

Our selection software for a precise bellhousing design is available free of charge here:
<https://login.hbe-hydraulics.com>.

RIGID BELLHOUSINGS ACC. TO VDMA 24561 FORM A

FOR ELECTRIC MOTORS FRAME IMB 5-IMB 35-IM V1

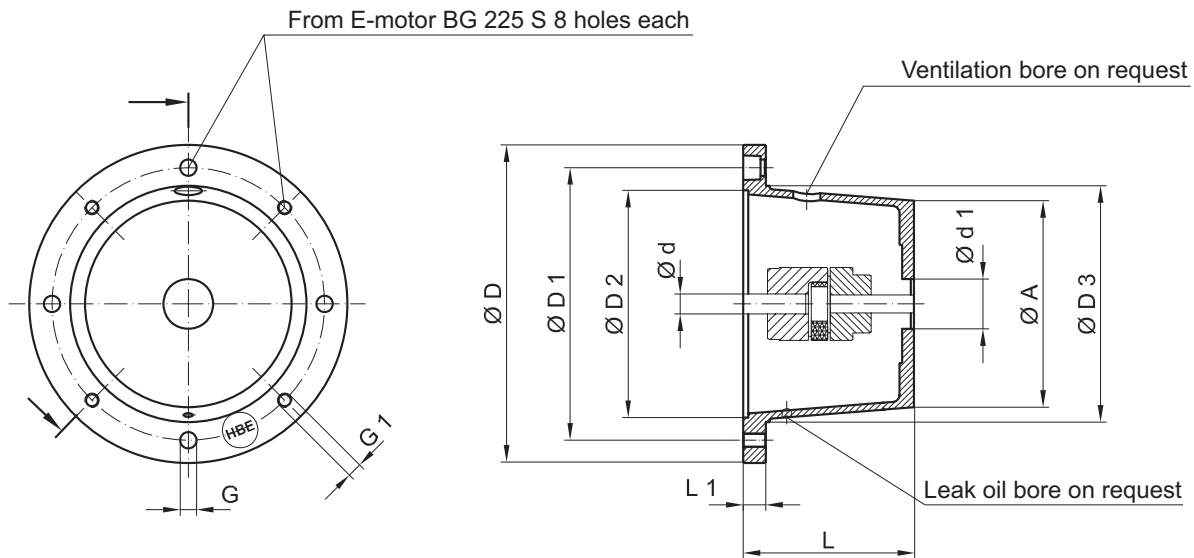

IEC motor size shaft (d x L)	kW at n=1500 min ⁻¹	Bellhousing	Foot flange	Gasket	Dimensions [mm]									
					Motor side								Pump side	
					Type	Type	Type	Ø D	Ø D1	Ø D2	Ø D3	L	L1	G
63 (11 x 23)	0.12-0.18	PR 140/95/...	-	D 140 GK	140	115	95	95	95	15	9	M8	90	25
		PR 140/105/...							105	25				
		PR 140/115/...							115	35				
71 (14 x 30)	0.25 - 0.37	PR 160/70/...*	PTFL 160	D 160 GK	160	130	110	110	70	13	9	M8	107	20
		PR 160/80/...*							80	13			106	20
		PR 160/90/...*							90	13			105	20
		PR 160/100/...							100	19			104	39
		PR 160/115/...							115	34			104	39
		PR 163/80-95/...**							80-95	19-34			164	60
		PR 163/100-115/...**							100-115	19-34			164	60
80 (19 x 40) 90 S + L (24 x 50)	0.55 - 0.75	PR 200/80/...	PTFL 200 PTFS 200	D 200 GK	200	165	130	145	80	16	11	M10	128	21
	1.1-1.5	PR 200/90/...							90				127	25
		PR 200/100/...*							100				127	25
		PR 200/110/...*							110				126	25
		PR 200/118/...*							118				126	25
		PR 200/124/...*							124				125	25
		PR 200/135/...							135				125	25
		PR 200/140/...*							140				125	25
		PR 203/105/...**							105				170	96
		PR 203/115/...**							115				170	96
		PR 203/124/... ...VDMA**							124				170	96
		PR 203/140/... ...VDMA**							140				170	96
	PR 203/148/...**	148							170				96	

*Design acc. to VDMA

**for horizontal installation only

IEC motor size shaft (d x L)	kW at n = 1500 min ⁻¹	Bellhousing	Foot flange	Gasket	Dimensions [mm]									
					Motor side								Pump side	
					Type	Type	Type	∅ D	∅ D1	∅ D2	∅ D3	L	L1	G
100 L 112 M (28 x 60)	2.2-4	PR 250/115/...	PTFL 250 PTFS 250	D 250 GK	250	215	180	190	115	19	14	M12	178	24
		PR 250/120/...*							120				178	24
		PR 250/124/...*							124				177	42
		PR 250/128/...*							128				177	42
		PR 250/135/...*							135				177	42
		PR 250/148/...*							148				176	58
		PR 250/175/...*							175				175	58
132 S+M (38 x 80)	5.5-7.5	PR 300/144/...*	PTFL 300 PTFS 300	D 300 GK	300	265	230	234	144	20	14	M12	224	35
		PR 300/150/...*							150				223	43
		PR 300/155/...*							155				223	50
		PR 300/168/...*							168				222	60
		PR 300/196/...*							196				220	77
		PR 300/210/...							210				220	77
160 M+L (42 x 110) 180 M+L (48 x 110)	11-15	PR 350/173/...	PTFL 350 PTFS 350	D 350 GK	350	300	250	260	173	25	18	M16	241	35
	18.5-22	PR 350/188/...*							188				238	50
		PR 350/204/...*							204				237	56
		PR 350/228/...*							228				240	77
		PR 350/256/...*							256				240	97
200 L (55 x 110)	30	PR 400/188/...*	PTFS 400	D 400 GK	400	350	300	300	188	25	18	M16	270	35
		PR 400/204/...*							204				267	60
		PR 400/228/...*							228				263	77
		PR 400/256/...*							256				258	97
		PR 400/271/...							271				258	97
225 S+M (60 x 140)	37-45	PR 450/217/...	PTFS 450	D 450 GK	450	400	350	350	217	25	18	M16	300	47
		PR 450/222/...							222				299	50
		PR 450/234/...*							234				296	50
		PR 450/240/...							240				295	80
		PR 450/262/...*							262				290	100
		PR 450/285/...*							285				286	100
		PR 450/315/...*							315				280	100
250 M (65 x 140) 280 S+M (75 x 140)	55	PR 550/230/...	PTFS 550	D 550 GK	550	500	450	450	230	25	18	M16	362	50
	75-90	PR 550/248/...*							248				359	100
		PR 550/265/...*							265				356	100
		PR 550/275/...*							275				354	120
		PR 550/295/...*							295				350	120
		PR 550/315/...*							315				347	120
315 S+M 315 L (80 x 170)	110-200	PR 660/310/...*	PTFS 660	D 660 GK	660	600	550	550	310	32	22	M20	425	120
		PR 660/330/...*							330				416	120
		PR 660/345/...*							345				410	120
355 L/ 400 L (100 x 210)	250-400	PR 800/315/...	-	-	800	740	680	660	315	50	22	M20	443	145
		PR 800/360/...							360				425	120
		PR 800/380/...							380				416	120
		PR 800/395/...							395				410	120

*Design acc. to VDMA

BELLOUSINGS WITH DAMPING FLANGE ACC. TO VDMA 24561 FORM B

FOR ELECTRIC MOTORS FRAME IMB 5-IMB 35-IM V1

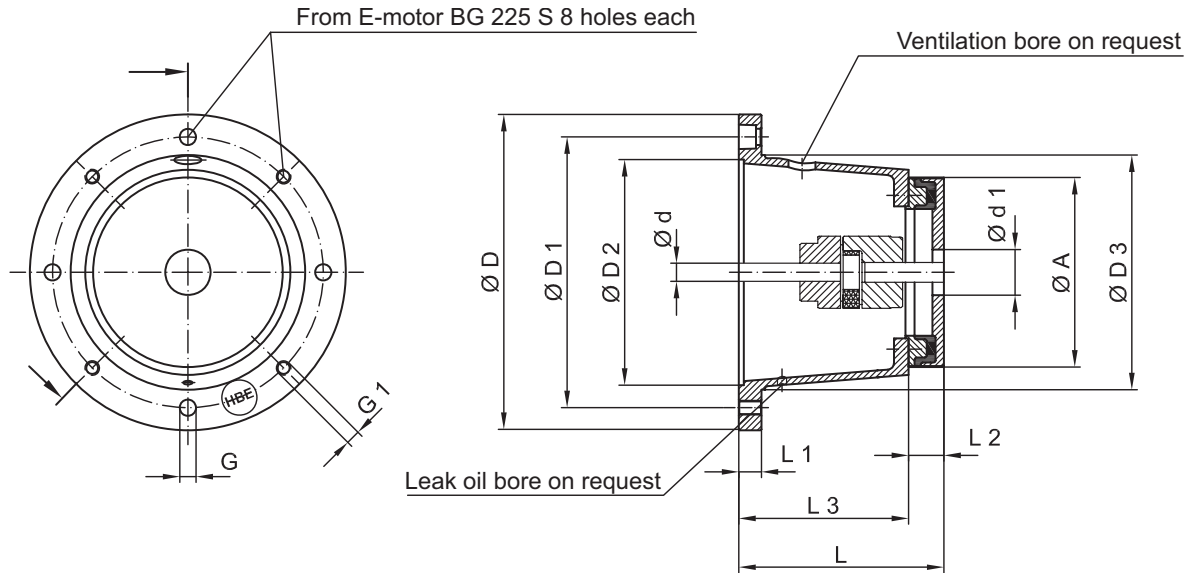

IEC motor size shaft (d x L)	kW at n= 1500 min ⁻¹	Bellhousing and damping flange	Foot flange	Gasket	Dimensions [mm]											
					Motor side										Pump side	
					Type	Type	Type	Ø D	Ø D1	Ø D2	Ø D3	L	L3	L2	L1	G
80 (19 x 40)	0.55-0.75	PR200/100 DF200/*	PTFL 200 PTFS 200	D 200 GK	200	165	130	145	100	70	30	16	9	M8	139	31
		PR200/110 DF200/*							110	80		16				
	PR200/118 DF200/*	118							88	14		16				
	PR200/124 DF200/*	124							94	30						
	PR200/140 DF200/*	140							110	16						
90 S + L (24 x 50)	1.1-1.5	PR250/120 DF250/*	PTFL 250 PTFS 250	D 250 GK	250	215	180	190	120	85	35	25	14	M12	186	32
		PR250/124 DF200/*							124	94	30	18				
		PR250/128 DF250/*							128	93	35	19				
		PR250/135 DF250/*							135	100	35	19				
		PR250/148 DF200/*							148	120	28	19				
		PR250/148 DF250/*							148	115	33	19				
		PR250/175 DF250/*							175	140	35	18				
100 L 112 M (28 x 60)	2.2-4	PR300/144 DF250/*	PTFL 300 PTFS 300	D 300 GK	300	265	230	234	144	109	35	20	14	M12	186	32
		PR300/150 DF200/*							150	120	30					
		PR300/150 DF250/*							150	115	35					
		PR300/155 DF250/*							155	120	35					
		PR300/155 DF300/*							155	115	40					
		PR300/168 DF250/*							168	133	35					
		PR300/195 DF300/*							195	155	40					
132 S+M (38 x 80)	5.5-7.5	PR300/144 DF250/*	PTFL 300 PTFS 300	D 300 GK	300	265	230	234	144	109	35	20	14	M12	186	32
		PR300/150 DF200/*							150	120	30					
		PR300/150 DF250/*							150	115	35					
		PR300/155 DF250/*							155	120	35					
		PR300/155 DF300/*							155	115	40					
		PR300/168 DF250/*							168	133	35					
		PR300/195 DF300/*							195	155	40					

*Design acc. to VDMA

IEC motor size shaft (d x L)	kW at n= 1500 min ⁻¹	Bellhousing and damping flange	Foot flange	Gasket	Dimensions [mm]											
					Motor side									Pump side		
					Type	Type	Type	∅ D	∅ D1	∅ D2	∅ D3	L	L3	L2	L1	G
160 M+L (42 x110) 180 M+L (48 x110)	11-15	PR 350/188 DF 250/...*	PTFL 350 PTFS 350	D 350 GK	350	300	250	260	188	153	35	25	18	M16	186	32
		204							164	40	222				32	
	228	188							40	222	32					
	256	211							45	258	46					
200 L (55 x110)	30	PR 400/204 DF 300/...*	PTFS 400	D 400 GK	400	350	300	300	204	164	40	25	18	M16	222	32
		228							188	40	222				32	
		256							211	45	258				46	
225 S+M (60 x140)	37-45	PR 450/234 DF 300/...*	PTFS 450	D 450 GK	450	400	350	350	234	194	40	25	18	M16	222	32
		262							222	40	222				32	
		262							217	45	258				46	
		285							240	45	258				46	
		315							270	45	258				46	
250 M (65 x140) 280 S (75 x140)	55	PR 550/248 DF 350/...*	PTFS 550	D 550 GK	550	500	450	450	248	203	45	25	18	M16	258	46
		265							230	35	186				32	
		265							220	45	258				46	
		275							230	45	258				46	
	75-90	PR 550/275 DF 400/...*							275	215	60				365	120
		PR 550/293 DF 350/...*							293	248	45				258	46
		PR 550/315 DF 300/...*							315	275	40				222	32
		PR 550/315 DF 350/...*							315	270	45				258	46
315 S+M 315 L (80 x170)	110-200	PR 660/310 DF 350/...*	PTFS 660	D 660 GK	660	600	550	550	310	265	45	32	22	M20	258	46
		330							285	45	258				46	
		345							300	45	258				46	
		345							285	60	365				120	
355 L/400 L (100 x 210)	250-400	PR 800/360 DF 350/...	-	-	800	740	680	680	360	315	45	50	22	M20	258	46
		375							315	60	365				120	
		380							335	45	258				46	
		395							335	60	365				120	
		410							350	60	365				120	

*Design acc. to VDMA

RADIAL WEIGHT LOAD

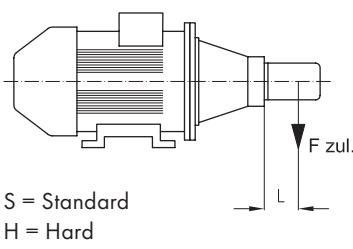

$$F_{zul} = \frac{(F[N] \times L)}{\text{effective SPA}^{**}}$$

Damping flange	DF 200/...		DF 250/16		DF 300/32		DF 350/63		DF 400/84	
	S	H	S	H	S	H	S	H	S	H
Centroidal distance for radial load L [mm]	70		100		100		200		200	
Permittable weight load F _{zul} [N]***	300	400	1100	1300	1600	1900	1400	2000	3000	4000

** Centroidal distance

*** for operating temperature up to 60°C

BELLOUSINGS FOR RECTANGULAR PUMP CONNECTIONS

IEC motor size shaft (d x L)	kW at n= 1500 min ⁻¹	Frame	Bellhousing	Foot flange	Gasket	Dimensions [mm]													
						Motor side								Pump side					
						Type	Type	Type	øD	øD1	øD2	øD3	L	L1	G	G1	ø A	ø A1	ø A2
63 (11 x 23)	0.12-0.18	IMB 14	PE 90/60/...	-	-	90	75	60	62	60	10	-	7	90	69	34	22		
			PE 120/85/...			120	100	80	80	85	12	-		87	67	32	22		
		IMB 5	PE 140/60/...			140	115	95	100	60	11	9	M8	90	69	34	22		
71 (14 x 30)	0.25-0.37	IMB 14	PE 105/70/...	-	D 140	105	85	70	70	70	10	9	7	90	69	34	22		
			PE 140/95/...			140	115	95	100	95	12		9	90	69	34	22		
		IMB 5	PRE 160/70/...			PTFL 160	D 160	160	130	110	110	70	13	9	M8	90	66	34	20
PE 160/95/...	95	14	120	90	45			21											
80 (19 x 40)	0.55-0.75	IMB 14	PE 120/85/...	-	-	120	100	80	80	85	12	-	7	120	67	32	22		
			PRE 160/80/...			PTFL 160	D 160	160	130	110	110	80	13	9	9	90	66	34	20
			PE 160/95/...					95	14	120	90	45	21						
		IMB 5	PRE 200/80/...	PTFL 200 PTFS 200	D 200	200	165	130	145	80	16	11	M10	Ø 128			21		
		PE 200/95/...	95			15	118	86	43	36.5									
PE 200/126/...	126	16	11			180	158	65	50.8										
90 S+L (24 x 50)	1.1-1.5	IMB 14	PE 140/95/...	-	D 140	140	115	95	100	95	12	9	9	120	90	45	25.4		
			PRE 160/90/...			PTFL 160	D 160	160	130	110	110	90	13	9	9	90	66	34	20
			PE 160/105/...					105	24	120	90	45	21						
		IMB 5	PRE 200/90/...	PTFL 200 PTFS 200	D 200	200	165	130	145	90	16	11	M10	Ø 127			25		
PE 200/126/...	126	16	M11			180	158	65	50.8										
100 L 112 M (28 x 60)	2.2-4	IMB 14	PE 160/108/...	PTFL 160	D 160	160	130	110	110	108	27	9	9	120	90	45	21		
		IMB 5	PRE 250/115/...	PTFL 250 PTFS 250	D 250	250	215	180	190	115	19	14	M12	Ø 178			24		
132 S+M (38 x 80)	5.5-7.5	IMB 5	PRE 300/144/...	PTFL 300 PTFS 300	D 300	300	265	230	234	144	20		14	M12	Ø 224			36.5	
			PE 300/2/143							143	21	180			158	62	50.8		
160 M+L (42 x 110) 180 M+L (48 x 110)	11-15	IMB 5	PRE 350/173/...	PTFL 350 PTFS 350	D 350	350	300	250	260	173	25	18	M16	Ø 241			35		
	18.5-22		PRE 350/197/...							197				230	175	77	60		
200 L (55 x 110)	30	IMB 5	PRE 400/188/...	PTFS 400	D 400	400	350	300	300	188	25	18	M16	Ø 270			35		
225 S+M (60 x 140)	37-45	IMB 5	PRE 450/217/...	PTFS 450	D 450	450	400	350	350	217	25	18	M16	Ø 300			47		
			PRE 450/234/...							234				Ø 296			50		
250 M (65 x 140) 280 S+M (75 x 140)	55 75-90	IMB 5	PRE 550/230/...	PTFS 550	D 550	550	500	450	450	230	26	18	M 16	Ø 362			50		

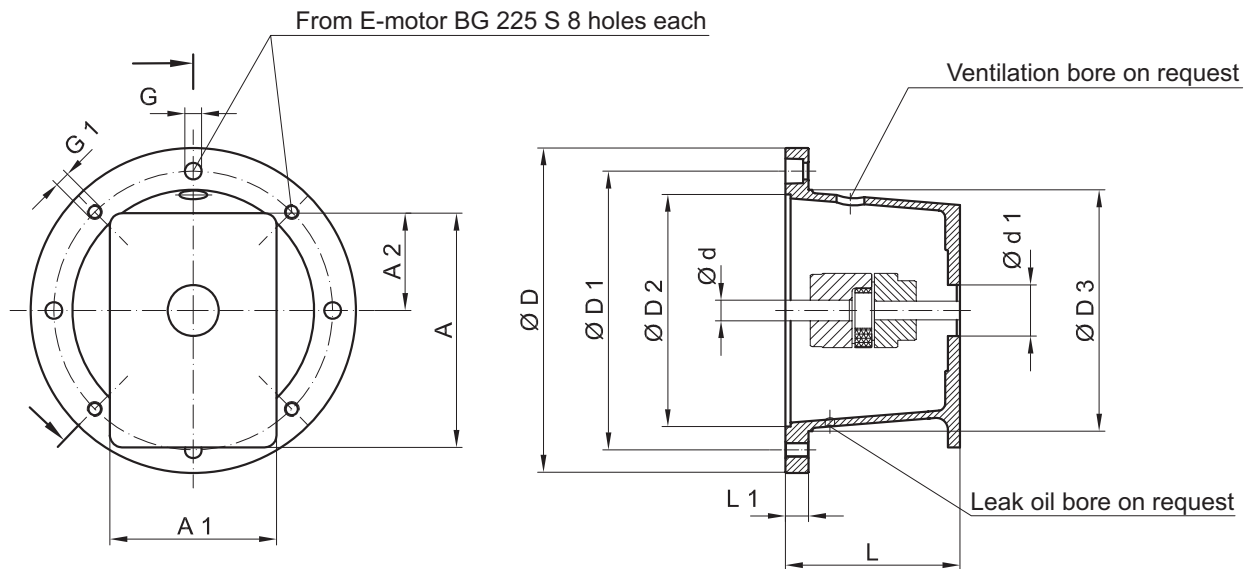

DIMENSIONS PUMP FACE CODE FOR GEAR PUMPS

BB: 05

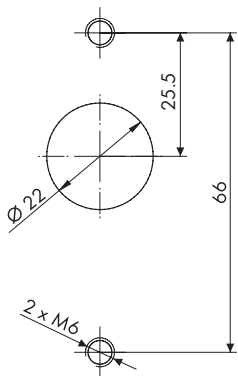

BB: 10

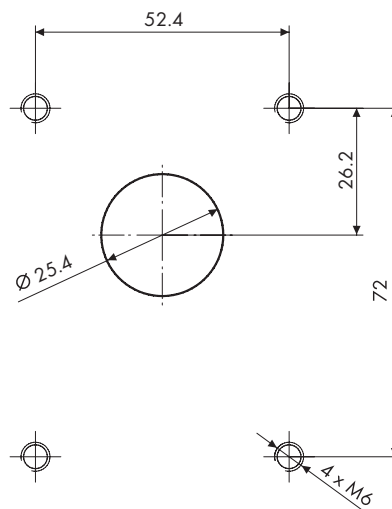

BB: 20

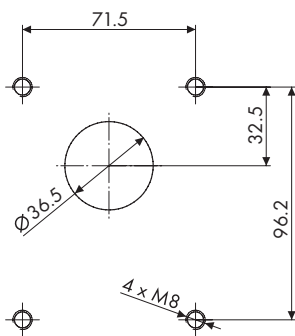

BB: 25/27

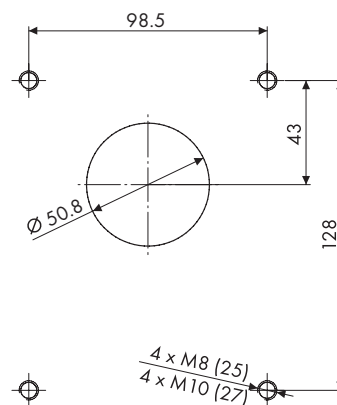

BELLOUSINGS FOR RECTANGULAR PUMP CONNECTIONS

DIMENSIONS PUMP FACE CODE FOR GEAR PUMPS

BB: 35

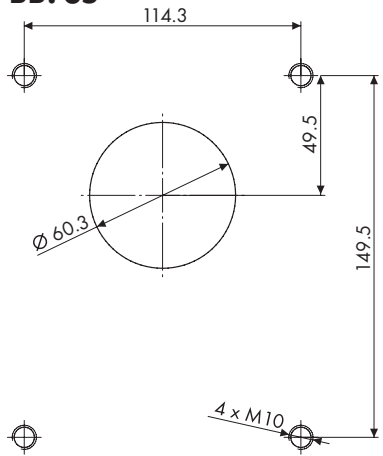

BB: 40

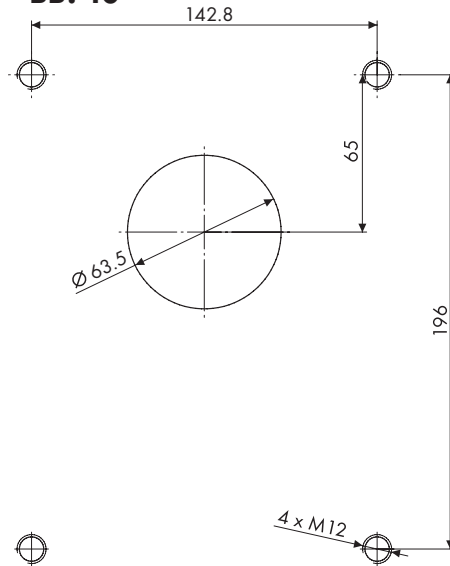

BB: 45

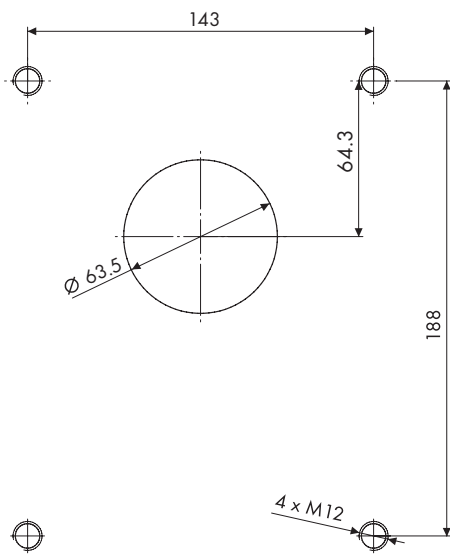

BB: 60

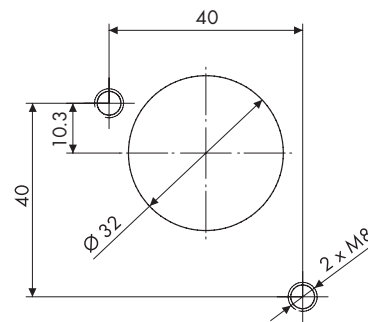

BB: 70

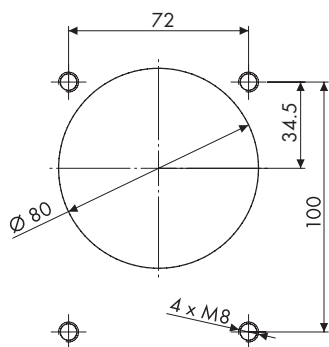

BB: 80

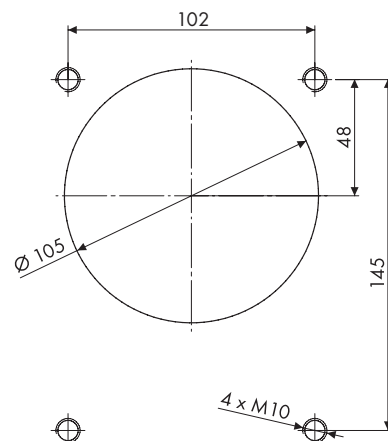

BASIC PROGRAMME BELLHOUSINGS FOR GEAR PUMPS

Type	Possible rectangular pump face code									
	5	10	20	25/27	35	40	45	60	70	80
PE 90/60/...	•	•						•		
PE 105/70/...	•	•						•		
PE 120/85/...	•	•	•					•		
PE 140/60/...	•	•						•		
PE 140/95/...	•	•	•					•	•	
PRE 160/70/...	•	•						•		
PRE 160/80/...	•	•						•		
PRE 160/90/...		•						•		
PE 160/95/...			•						•	
PRE 200/80/...	•	•						•		
PRE 200/90/...		•						•		
PE 200/95/...									•	
PE 200/100/...			•						•	
PRE 200/100/...		•								
PE 200/126/...				•						•
PRE 250/110/...		•	•					•		
PRE 250/115/...		•	•	•				•	•	
PRE 300/144/...			•	•					•	
PRE 350/173/...			•	•	•				•	•
PRE 350/197/...					•	•	•			•
PRE 400/188/...					•					•
PRE 450/217/...					•					•
PRE 450/234/...										•
PRE 550/230/...					•	•	•			•

RECTANGULAR BELLHOUSINGS WITH DAMPING FLANGE DF-ZRP

PRODUCT DESCRIPTION

- Reduction of noise level of the pump / motor unit up to 5 dB (A) possible, depending on pump construction
- Standard bellhousing made of aluminium, damping flange made of aluminium / perbunan vulcanised
- No metallic connection
- Horizontal and vertical application possible
- Resistance: mineral oil max. 80°C

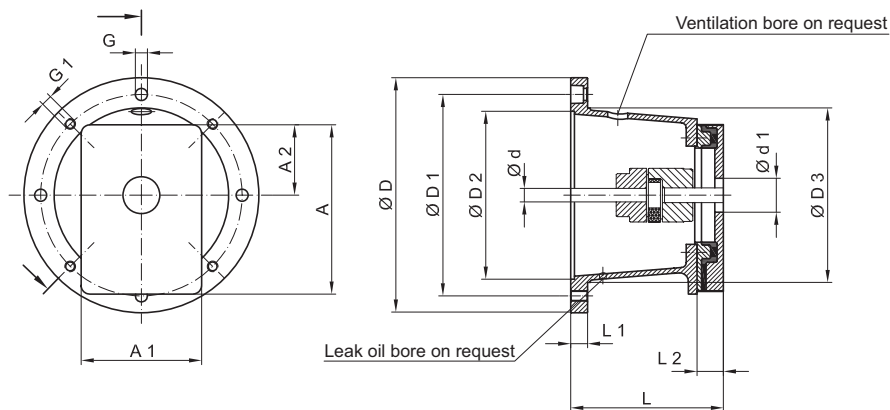

Order code

Type	Size	Total length	DF type	Pump face code
PE	250	124	DFZRP	433/1

IEC motor size shaft (d x L)	kW at n= 1500 min ⁻¹	Frame	Bell-housing and damping flange	Foot flange	Gasket	Dimensions [mm]												
						Motor side								Pump side				
						Type	Type	Type	ØD	ØD1	ØD2	ØD3	L	L1	L2	G	G1	øA
71 (14 x 30)	0.25-0.37	IMB 5 IMV 1	PRE 160/90 DFZRP/...	PTFL 160	D 160GK	160	130	110	110	90	13	20	9	M8	121	92	46	22
80 (19 x 40)	0.55-0.75	IMB 14	PRE 160/90 DFZRP/...	PTFL 160	D 160 GK	160	130	110	110	90	14	20	9	9	121	92	46	22
		IMB 5 IMV 1	PRE 200/100 DFZRP/... PRE 200/118 DFZRP/...	PTFL 200 PTFS 200	D 200 GK	200	165	130	145	100 118	16 15	11	M10					
90 S+L (24 x 50)	1.1-1.5	IMB 14	PRE 160/90 DFZRP/...	PTFL 160	D 160 GK	160	130	110	110	90	13	20	9	9	121	92	46	22
		IMB 5 IMV 1	PRE 200/ 100 DFZRP/... PRE 200/ 118 DFZRP/...	PTFL 200 PTFS 200	D 200 GK	200	165	130	145	100 118	16 15	11	M10					
100 L 112 M (28 x 60)	2.2-4	IMB 14	PRE 160/110 DFZRP/...	PTFL 160	D 160 GK	160	130	110	110	110	34	20	9	9	121	92	46	22
		IMB 5 IMV 1	PRE 250/114 DFZRP/...	PTFL 250 PTFS 250	D 250 GK	250	215	180	190	114	19	14	M12					
132 S+M (38 x 80)	5.5-7.5	IMB 5 IMV 1	PRE 300/153 DFZRP/...	PTFL 300 PTFS 300	D 300 GK	300	265	230	234	153	20	20	14	M12	121	92	46	22

For higher driving power of motor sizes 160 - 280 please see dimension sheet "round bellhousing with damping flange" on page 82 f.

RECTANGULAR BELLHOUSINGS FOR HONDA INDUSTRY MOTORS

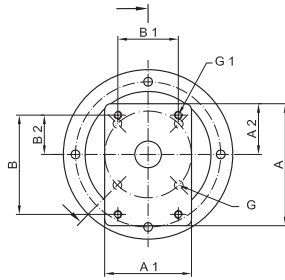

GX 100 - 160

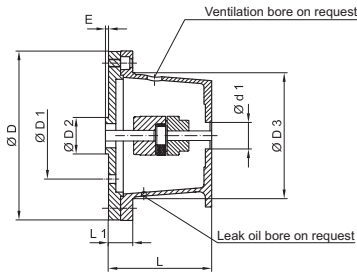

GX 240 - 390

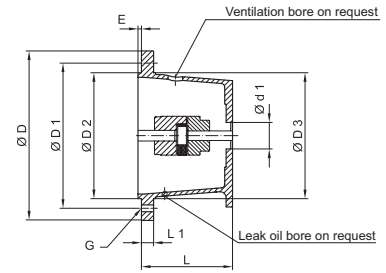

Motor type	Shaft	Bellhousing	Pump side cone	Coupling	Dimensions [mm]																						
					Motor side								Pump side														
					Type	Type	Type	ØD	ØD1	ØD2	ØD3	L	L1	E	G	ØA	ØA1	ØA2	d1	B	B1	B2	G1				
GX 100	S	PE 160/95/10 HO	1:8	24/30 N1-15	160	92	41.2	110	95	39	2.5	9	90	69	34	25.4	72	52.4	26.2	M6							
	Q	PE 160/105/10 HO		24/30 N1-ED					105	49																	
GX 110 GX 120/120 K1	S + L	PE 160/95/10 HO	1:8	24/30 N1-18 N5	160	92	41.2	110	95	39	2.5	9	90	69	34	25.4	72	52.4	26.2	M6							
	H	PE 160/95/10 HO		24/30 N1-A					95	39																	
GX 140 GX 160/160 K1	S + L	PE 160/95/10 HO	1:8	24/30 N1-20N5	160	92	41.2	110	95	39	2.5	9	90	69	34	25.4	72	52.4	26.2	M6							
		PE 160/110/20 HO	1:8	24/30 N2(a)-20N5					110	29											120	90	45	36.5	96	71.5	32.5
	PE 160/110/70 HO	1:5	24/30 B17-20N5	110					29	120											90	45	80	100	72	34.5	M8
	H	PE 160/95/10 HO	1:8	24/30 N1-A					95	39											90	69	34	25.4	72	52.4	26.2
Q	PE 160/105/10 HO	1:8	24/30 N1-A					105	49																		
GX 240/240 K1	S + L	PE 160/108,5/10 HO	1:8	24/30 N1-25 N7	160	127	110	110	108.5	27.5	2.5	9	120	90	45	25.4	72	52.4	26.2	M6							
GX 270		PE 160/108,5/20 HO	1:8	28/38 N2 (a) K25N7																	36.5	96	71.5	32.5	M8		
GX 340/340 K1 GX 390/390 K1		PE 160/108,5/70 HO	1:5	28/38 B17-25 N7																	80	100	72	34.5	M8		

RECTANGULAR BELLHOUSINGS FOR KUBOTA INDUSTRY MOTORS

Motor type	Shaft	Bellhousing	Pump side cone	Coupling	Dimensions [mm]																				
					Motor side								Pump side												
					Type	Type	Type	ØD	ØD1	ØD2	ØD3	L	L1	E	G	ØA	ØA1	ØA2	d1	B	B1	B2	G1		
OC 60 OC 80 OC 95	Q	PE 160/130/10 KU	1:8	24/30 N1-BS 98°	160	113.1	146.1	110	130	49	2	9	120	90	45	25.4	72	52.4	26.2	M6					
		PE 160/133/20 KU		MB 28 N2 (a)-BS					133	56											36.5	96	71.5	32.5	M8
		PE 160/133/70 KU		24/30 B17-BS 98°					133	56											80	100	72	34.5	M8
GH 120 GH 170	Q	PE 160/105/10 KU	1:8	24/30 N1-A 98°	160	92	41.2	110	105	49	2.5	9	90	69	34	25.4	72	52.4	26.2	M6					
		PE 160/115/20 KU		24/30 N1-(a)-A98°					110	34											120	90	45	36.5	96
		PE 160/115/70 KU	1:5	24/30 B17-A 98°				110	115	34			120	90	45	80	100	72	34.5	M8					

BELLOUSINGS FOR NEMA MOTORS, RIGID TYPE TD (US STANDARD)

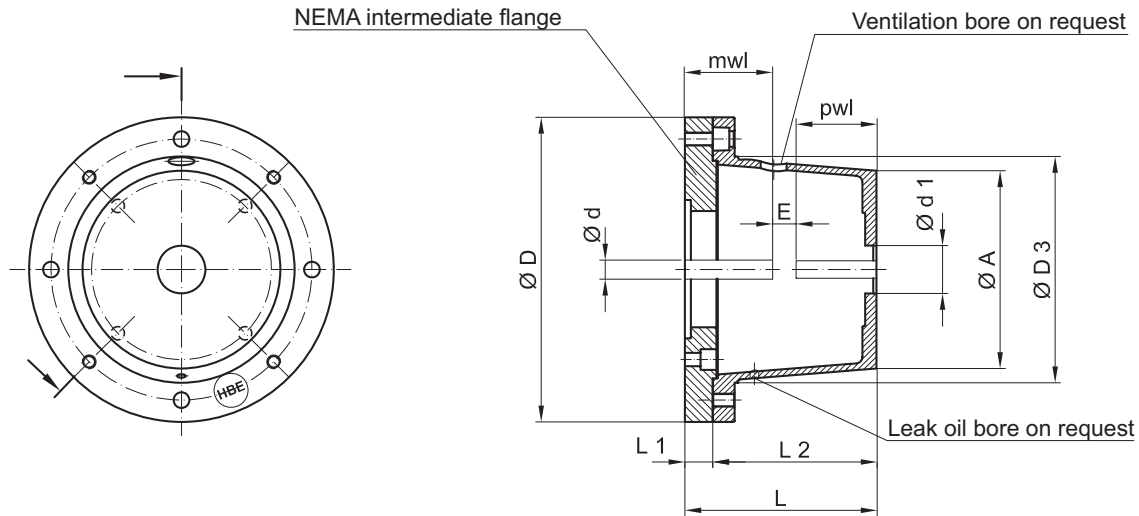

NEMA motor 60 Hz 1800 min ⁻¹	HP	mwL	ø d code	Bellhousing	NEMA intermediate flange	Dimensions [mm]							Softex® coupling	E					
						L	L1	L2	øD	ød1	øD3	øA							
143-145 TD	0.5-2	57.2	G	PR 250/115	ZF 295/25 PR 250/NEMA (5454)	140	25	115	295	250	190	178	19/24	16					
				PR 250/120		145		120				178							
182-184 TD	3-5	70.0	SB	PR 250/124		149		124				177							
				PR 250/128		153		128				177	24/30	18					
213-215 TD	7.5-10	85.7	M	PR 250/135		160		135				177							
				PR 250/148		173		148				176	28/38	20					
254-256 TD	15-20	101.6	N	PR 300/144		ZF 350/26 PR 300/NEMA (5451)		171				26	144	350	300	234	223	38/45	24
				PR 300/150				176					150				223		
284-286 TD	25-30	117.5	NM	PR 300/155	181		155	223											
				PR 300/168	194		168	222	42/55	26									
				PR 300/196	222		196	220											
324-326 TD	40-50	133.3	P	PR 450/217*	242		217	300											
				PR 450/222	247		222	299	48/60	28									
364-365 TD	60-75	149.2	UB	PR 450/234*	ZF 450/25 PR 450/NEMA (5477)		259	25	234	450	450		350				296	55/70	30
				PR 450/240		265	240		295										
				PR 450/262		287	262		290										
				PR 450/285		310	285		286										
				PR 550/230		255	230		362										
404-405 TD	100	184.2	WA	PR 550/248		273	248		359										
				PR 550/265		290	265		356										
444-445 TD	125-150	215.9	WD	PR 550/275		ZF 550/25 PR 550/NEMA (5478)	300		25			275		550	550	450	354	75/90	40
				PR 550/295*	320		295	350											
				PR 550/315	340		315	347											

*one piece version

ORDERING EXAMPLE: DETERMINATION OF THE TOTAL LENGTH OF THE BELLHOUSING MOTOR 213-215 TC

pwl = Total length of the pump shaft incl. centring collar + possible difference, if coupling hub is longer than the carrying length of the pump shaft.

pwl (length of pump shaft) e.g.	= 50 mm
mwL (total length of motor shaft) e.g.	= 79.4 mm
E (distance between motor and pump shaft type 28/38)	= 20 mm
Total length theoretical L	= 149.4 mm
Total length available L	= 153 mm

BELLOUSINGS FOR NEMA MOTORS, RIGID TYPE C-TC (US STANDARD)

NEMA motor 60 Hz 1800 min ⁻¹	HP	mwL	ø d code	Bellhousing	NEMA intermediate flange	Dimensions [mm]							Softex® coupling	E
						L	L1	L2	øD	ød1	øD3	øA		
56 C	0.25- 0.75	54.2	ED	PR 200/80	ZF 200/18 PR 200 56-145 TC (5476)	98	18	80	200	200	145	128	19/24	16
				PR 200/90		108		90				127		
				PR 200/100		118		100				127		
				PR 200/110		128		110				126		
				PR 200/118		136		118				126		
143-145 TC	0.5-2	54	G	PR 250/115	ZF 250/23 PR 250 56-145 TC (5467)	138	23	115	250	250	190	178		
				PR 250/120		143		120				178		
				PR 250/124		147		124				177		
				PR 250/128		151		128				177		
				PR 250/135		158		135				177		
182-184 TC	3-5	66.7	SB	PR 250/115	ZF 250/18 PR 250 182-256 TC (5453)	133	18	115	250	250	190	178	24/30	18
				PR 250/120		138		120				178		
213-215 TC	7.5-10	79.4	M	PR 250/124	ZF 250/18 PR 250 182-256 TC (5453)	142	18	124	250	250	190	177	28/38	20
				PR 250/128		146		128				177		
				PR 250/135		153		135				177		
254-256 TC	15-20	95.3	N	PR 250/148	ZF 250/18 PR 250 182-256 TC (5453)	166	18	148	250	250	190	176	38/45	24
				PR 250/175		193		175				175		
182-184 TC	3.5	66.7	SB	PR 300/144	ZF 300/20 PR 300 182-256 TC (5480)	164	20	144	300	300	234	224	24/30	18
				PR 300/150		170		150				223		
213-215 TC	7.5-10	79.4	M	PR 300/155	ZF 300/20 PR 300 182-256 TC (5480)	175	20	155	300	300	234	223	28/38	20
				PR 300/168		188		168				222		
254-256 TC	15-20	95.3	N	PR 300/196	ZF 300/20 PR 300 182-256 TC (5480)	216	20	196	300	300	234	220	38/45	24
284-286 TC	25-30	111.1	NM	PR 300/133	ZF 300/20 PR 300 284-286 TC (5475)	153	20	133	300	300	234	224	42/55	26
				PR 300/144		164		144				224		
				PR 300/150		170		150				223		
				PR 300/155		175		155				223		
				PR 300/168		188		168				222		
				PR 300/196		216		196				220		
				PR 300/210		230		210				218		
324-326 TC	40-50	127.0	P	PR 350/188	ZF 350/25 PR 350 324-405 TC (5449)	213	25	188	350	350	260	238	48/60	28
				PR 350/204		229		204				237		
364-365 TC	60-75	142.9	UB	PR 350/228	ZF 350/25 PR 350 324-405 TC (5449)	253	25	228	350	350	260	235	55/70	30
404-405 TC	100	184.2	WA	PR 350/256	ZF 350/25 PR 350 324-405 TC (5449)	281	25	256	350	350	260	232	75/90	40
444-445 TC	125- 150	215.9	WD	PR 550/248	ZF 550/34 PR 550 444-445 TC (5479)	282	34	248	550	550	450	359	75/90	40
				PR 550/265		299		265				356		
				PR 550/275		309		275				354		
				PR 550/295		329		295				350		
				PR 550/315		349		315				347		

BELLOUSINGS IN CAST IRON OR STEEL

PRODUCT DESCRIPTION

- Bellhousings made of cast iron, steel or stainless steel according to VDMA standard 24561
- Motor and pump side fully finished
- Types PRG and PRGS primed, machined surfaces preserved
- Use for mining, offshore, mobile and most of heavy duty applications
- Type PRGS particularly adapted to servo motors with square flange suitable for highly dynamic drives
- Good damping features due to large mass
- High corrosion protection also against salt water
- Type PRST also available in stainless steel and in almost all special lengths



		Order code			
Type	Size	Length	Pump face code		
PRG	250	/	175	/	433/1
PRG	Cast iron				
PRGS	Cast iron for servo motors				
PRST	Steel				
PRVA	Stainless steel				

DIMENSIONS

Type PRGS From E-motor size 225S 8 holes each

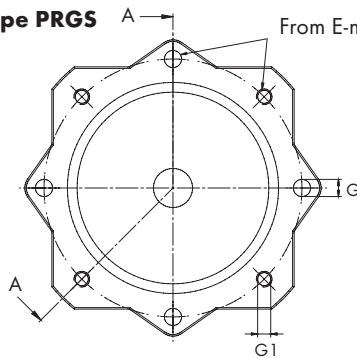

Type PRG/PRST

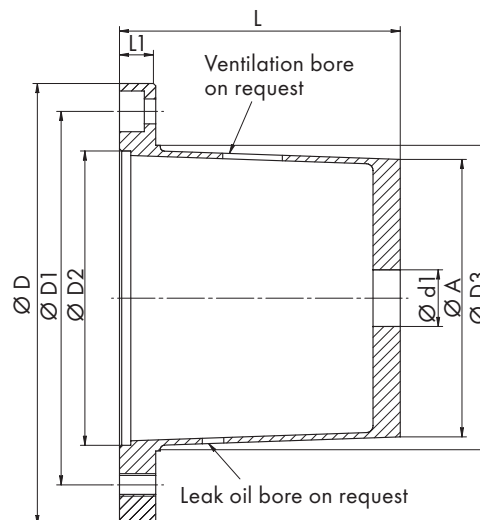
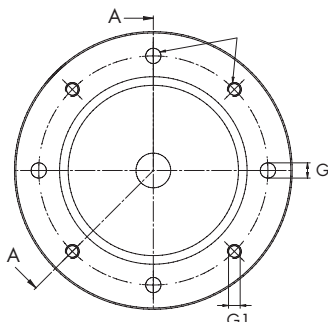

IEC motor size	kW at n=1500 min ⁻¹	Bell-housing Type	Foot flange	Gasket Type	Dimensions [mm]									
					Motor side							Pump side		
					ø D	ø D1	ø D2	ø D3	L* ^{**}	L1	G	G1	ø A	d1 _{min}
80 (19 x 40) 90 S + L (24x50)	0.55 - 0.75 1.1 - 1.5	PRST 200/100	PTFS 200 GG	D 200 GK	200	165	130	-	100	16	11	M10	*	*
		PRST 200/110						-	110				*	*
		PRST 200/118						-	118				*	*
		PRGS 200/124						145	124				142	25
		PRST 200/140						-	140				*	*
100 L 112 M (28 x 60)	2.2 - 4	PRST 250/120	PTFS 250 GG	D 250 GK	250	215	180	-	120	19	14	M12	*	*
		PRGS 250/124						190	124				185	25
		PRST 250/128						-	128				*	*
		PRST 250/135						-	135				*	*
		PRGS 250/148						190	148				185	40
		PRGS 250/175						190	175				225	70
132 S+M (38 x 80)	5.5 - 7.5	PRGS 300/144	PTFS 300 GG	D 300 GK	300	265	230	234	144	19	14	M12	225	30
		PRST 300/150						-	150				*	*
		PRST 300/155						-	155				*	*
		PRGS 300/168						234	168				225	60
		PRG 300/196						234	196				225	60
160 M+L (42 x 110) 180 M+L (48 x 110)	11 - 15 18.5 - 22	PRST 350/188	PTFS 350 GG	D 350 GK	350	300	250	-	188	25	18	M16	*	*
		PRST 350/204						-	204				*	*
		PRGS 350/228						260	228				255	77
		PRST 350/256						-	256				*	*
200 L (55 x 110)	30	PRST 400/204	PTFS 400 ST	D 400 GK	400	350	300	-	204	25	18	M16	*	*
		PRGS 400/228						300	228				280	77
		PRST 400/256						-	256				*	*
225 S+M (60 x 140)	37-45	PRST 450/234	PTFS 450 ST	D 450 GK	450	400	350	-	234	25	18	M16	*	*
		PRGS 450/262						260	262				258	90
		PRST 450/285						-	285				*	*
		PRST 450/315						-	315				*	*
250 M (65 x 140) 280 S+M (75 x 140)	55 75-90	PRST 550/248	PTFS 550 ST	D 550 GK	550	500	450	-	248	25	18	M16	*	*
		PRG 550/265						450	265				360	98
		PRST 550/275						-	275				*	*
		PRST 550/295						-	295				*	*
		PRST 550/315						-	315				*	*
315 S+M 315L (80 x 170)	110-200	PRST 660/310	PTFS 660 ST	D 660 GK	660	600	550	-	310	32	22	M20	*	*
		PRST 660/330						-	330				*	*
		PRST 660/345						-	345				*	*

*depending on the pump type **for type PRST variable lengths available on request

FOOT FLANGES ACC. TO VDMA 24561



LIGHT TYPE PTFL

PRODUCT DESCRIPTION

- PTFL: light and space saving type design
- Reduce the storage of E-motors to only one version in case of horizontal and vertical construction
- Use with horizontal installation of B5 motors
- Material: aluminium (D)
- Suitable damping rods on page 99
- All types available from stock

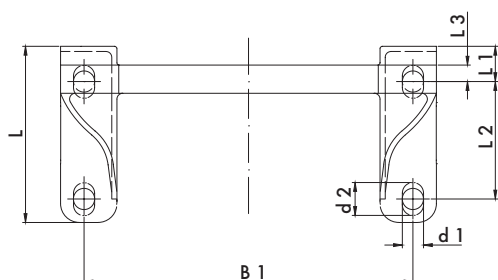
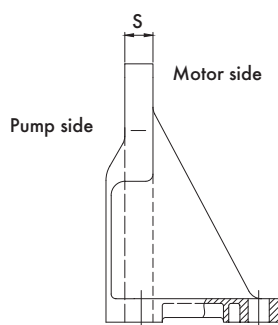
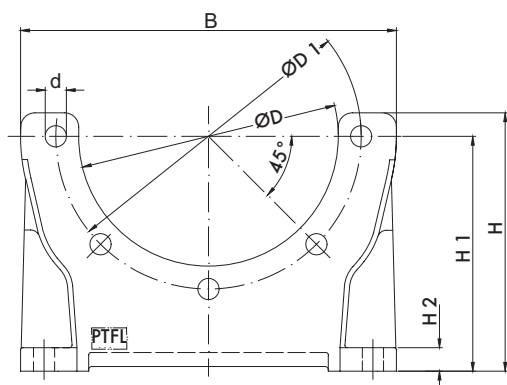

Art. No.	Type	Dimensions [mm]															Weight [kg]	Material
		ØD	ØD1	B	B1	L	L1	L2	L3	H	H1	H2	d	d1	d2	S		
4307	PTFL 160	110	130	160	140	75	15	50	7	110	100	10	9	9	-	12	0.25	Alu
4308-1	PTFL 200	145	165	200	180	88	15	60	4	124	112	12	11	11	-	14	0.41	Alu
4309-1	PTFL 250	190	215	250	220	110	21	60	-	145	132	15	14	14	22	14	0.55	Alu
4310-1	PTFL 300	235	265	300	260	120	22	80	-	172	160	18	14	14	22	18	0.90	Alu
4311-1	PTFL 350	260	300	348	300	148	20	110	-	195	180	18	18	18	24	18	1.50	Alu

FOOT FLANGES ACC. TO VDMA 24561



HEAVY TYPE PTFS

PRODUCT DESCRIPTION

- PTFS: heavy type especially suitable for multiple pumps
- Reduce the storage of E-motors to only one version in case of horizontal and vertical construction
- Use with horizontal installation of B5 motors
- Material: aluminium (D)
- Suitable damping rods on page 99
- All types available from stock

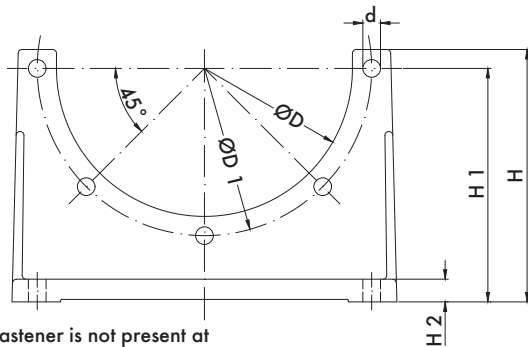

The fastener is not present at PTFS200, PTFS250 and PTFS300

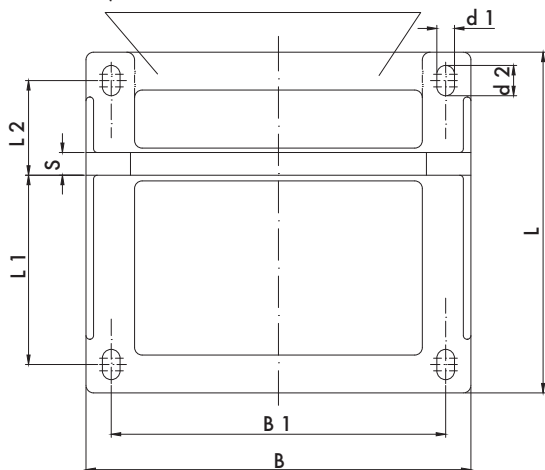
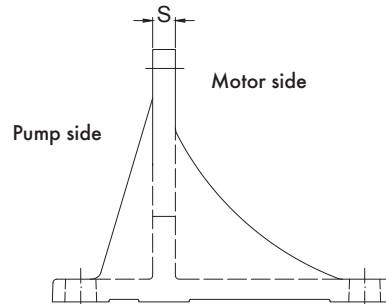

Art. No.	Type	Dimensions [mm]														Weight [kg]	Material
		ϕD	$\phi D1$	B	B1	L	L1	L2	H	H1	H2	d	d1	d2	S		
4316-2	PTFS 200	145	165	204	165	185	100	50	138	125	12	11	11	19	14	0.85	Alu
4317-2	PTFS 250	190	215	252	215	230	125	60	167	155	15	14	14	24	17	1.65	Alu
4318	PTFS 300	235	265	305	265	270	150	75	200	185	18	14	14	24	18	2.30	Alu
4319	PTFS 350	260	300	356	300	310	175	90	252	235	18	18	18	30	18	5.60	Alu
4320	PTFS 400	300	350	407	350	350	200	100	277	260	20	18	18	30	20	7.80	Alu
4321	PTFS 450	350	400	458	400	385	225	110	312	295	20	18	18	30	22	10.80	Alu
4322	PTFS 550	450	500	560	500	465	275	140	367	350	25	18	18	30	25	16.40	Alu
4323	PTFS 660	550	600	670	600	555	330	165	412	380	30	22	22	37	30	26.70	Alu

FOOT FLANGES IN STEEL ACC. TO VDMA 24561



PRODUCT DESCRIPTION

- PTFS heavy type
- Suitable for highly dynamic drives
- Suitable for mining, offshore, mobile and most of heavy duty applications
- Reduce the stocking of E-motors to only one version in case of horizontal and vertical construction
- Use with horizontal installation of B5 motors
- All types primed

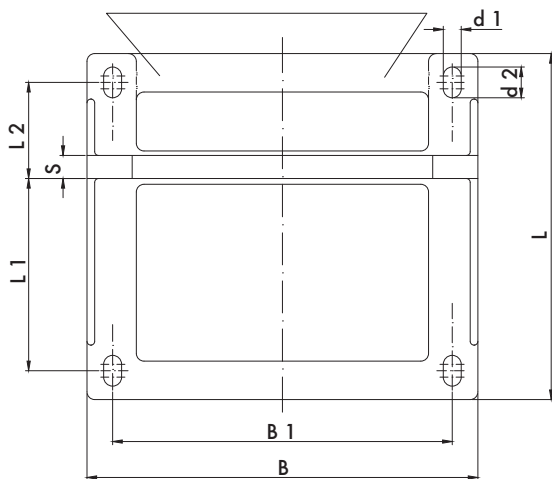
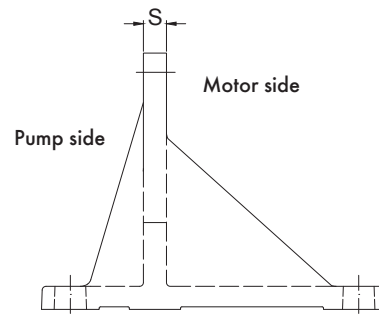
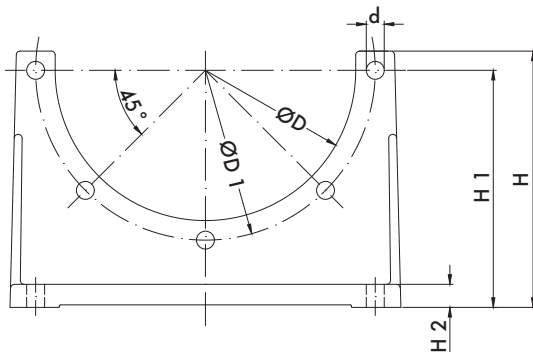

Art. No.	Type	Dimensions [mm]														Weight [kg]	Material
		øD	øD1	B	B1	L	L1	L2	H	H1	H2	d	d1	d2	S		
4316-3	PTFS 200	145	165	204	165	185	100	50	138	125	12	11	11	19	14	7.50	ST
4317-3	PTFS 250	190	215	252	215	230	125	60	167	155	13	14	14	24	15	8.00	ST
4318-1	PTFS 300	235	265	300	265	270	150	75	200	185	13	14	14	24	15	9.30	ST
4319-2	PTFS 350	260	300	350	300	310	175	90	252	235	13	18	18	30	15	13.20	ST
4320-2	PTFS 400	300	350	400	350	350	200	100	275	260	13	18	18	30	15	16.50	ST
4321-1	PTFS 450	350	400	458	400	385	225	110	312	295	20	18	18	30	22	20.00	ST
4322-1	PTFS 550	450	500	560	500	465	275	140	367	350	25	18	18	30	25	38.00	ST
4323-1	PTFS 660	550	600	670	600	555	330	165	415	380	30	22	22	37	30	50.00	ST

DAMPING ELEMENTS

DAMPING RODS

- Reduce the sound level and dampen vibrations
- Finished for IEC motors IMB 35 (MDS), NEMA motors, PTFL foot brackets (PTFL-DS) and PTFS foot brackets (PTFS-DS)
- Available from stock
- Special lengths and designs possible on request
- Material: Rubber (NR) / steel



Order code damping rods	
Type	Size
MDS	225 M

DAMPING FLANGES

- HBE damping flanges are applied in connection with HBE bellhousings or pump brackets between hydraulic pumps and E-motors
- They consist of two aluminium components, which are connected to each other by a moulded-on rubber coating (perbunan-NBR) without metallic contact
- The materials applied are resistant to mineral oils and are suitable for working temperatures up to + 80°C, temporary +100°C
- For optimisation, two different shore hardnesses are available: S = standard H = hard

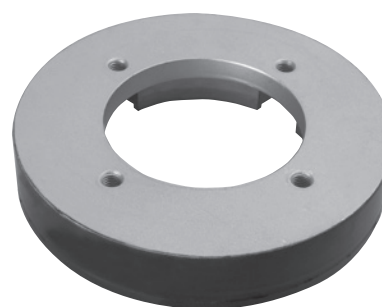

Order code damping flanges		
Type	Size	Pump face code
DF	250	586/1

DAMPING RINGS

- For application between bellhousing and tank vertically or horizontally
- Damping rings consist of two vulcanised perbunan coated combined aluminium rings
- Application: mineral oil up to max. +80°C
- Noise reduction: approx. 3 - 5 dB (A)
- Sealing lips moulded-on, no additional sealing necessary



Exemplary illustration of a breakaway quick-closing device

Order code damping rings		
Type	Size	Option
DA	400	/2

DAMPING RODS

TYPE MDS FOR ELECTRIC MOTORS FRAME IM B 35

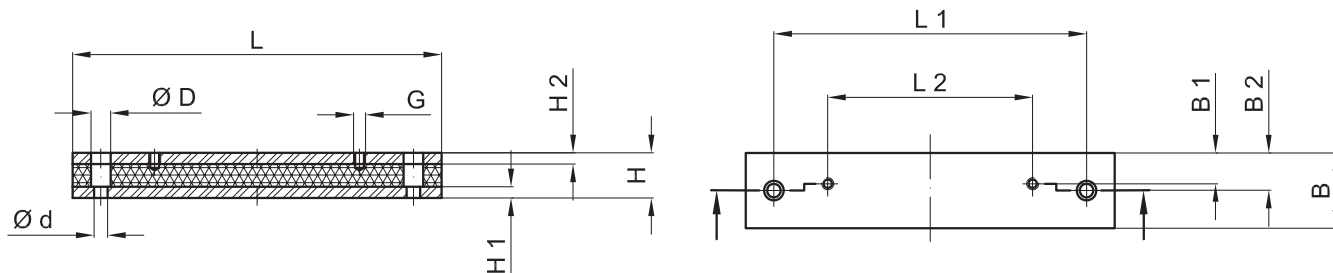

Art. No.	Type	IEC motor size	Dimensions [mm]												Shore° A
			L	L1	L2	H	H1	H2	B	B1	B2	Ø d	Ø D	G	
4420	MDS 71	71	196	156	90	40	10	10	50	21	25	14	20	M6	55°
4421	MDS 80	80	180	156	100	40	10	10	50	22	25	14	20	M8	
4447	DSM 80 SO	80	176	146	100	40	10	10	50	22	25	14	20	M8	
4421	MDS 90 S	90 S	180	156	100	40	10	10	50	22	25	14	20	M8	
4423	MDS 90 L	90 L	240	205	125	40	10	10	50	24	25	14	20	M8	
4424	MDS 100 L	100 L	240	205	140	40	10	10	50	24	25	14	20	M10	
4425	MDS 112 M	112 M	240	205	140	40	10	10	50	20	25	14	20	M10	
4427	MDS 132 S	132 S	285	245	140	45	10	10	50	20	25	14	20	M10	
4427	MDS 132 M	132 M	285	245	178	45	10	10	50	20	25	14	20	M10	
4428	MDS 160 M	160 M	340	300	210	60	15	15	70	28	35	18	26	M12	
4429	MDS 160 L	160 L	416	370	254	60	15	15	70	28	35	18	26	M12	
4430	MDS 180 M	180 M	416	370	241	60	15	15	70	35	35	18	26	M12	
4431	MDS 180 L	180 L	446	400	279	60	15	15	70	35	35	18	26	M12	
4432	MDS 200 L	200 L	496	430	305	60	15	15	70	35	35	22	33	M16	
4433	MDS 225 S	225 S	496	430	286	60	15	15	70	35	35	22	33	M16	
4434	MDS 225 M	225 M	496	445	311	60	15	15	70	35	35	22	33	M16	
4435	MDS 250 M	250 M	496	445	349	60	15	15	100	50	50	22	33	M20	
4436	MDS 280 S	280 S	580	530	368	60	15	15	100	50	50	22	33	M20	
4436	MDS 280 M	280 M	580	530	419	60	15	15	100	50	50	22	33	M20	
4441	DSM 280 S-SO	280 S	614	570	368	60	15	15	100	50	50	22	33	M20	
4437	DSM 280 M-SO	280 M	614	570	419	60	15	15	100	50	50	22	33	M20	
4438	MDS 315 S	315 S	614	570	406	60	15	15	100	60	60	22	33	M24	
4443	MDS 315 M	315 M	614	570	457	60	15	15	100	60	60	22	33	M24	
4389	DSM 315 S	315 S	614	570	406	60	15	15	120	60	60	22	33	M24	
4389	DSM 315 M	315 M	614	570	457	60	15	15	120	60	60	22	33	M24	
4446	MDS 315 L	315 L	704	660	508	60	15	15	100	60	60	22	33	M24	
4446-1	DSM 315 L	315 L	704	660	508	60	15	15	120	60	60	22	33	M24	
4449	MDS 355 M	355 M	826	782	630	60	15	15	100	60	60	22	33	M24	

TYPE MDS FOR ELECTRIC MOTORS FRAME NEMA TC + TD

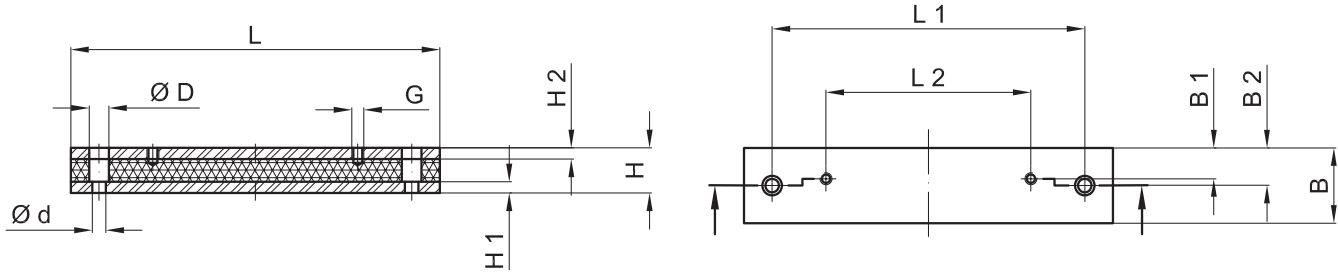

Art. No.	Type	Motor size	Dimensions [mm]												
			L	L1	L2	H	H1	H2	B	B1	B2	Ød	ØD	G	Shore° A
4422	MDS 143 TC/TD NEMA	143 TC/TD	190	160	101.6	40	10	10	50	20	25	14	20	M8	55°
5692	MDS 145 TC/TD NEMA	145 TC/TD	225	185	127.0	40	10	10	50	20	25	14	20	M8	
5693	MDS 182 TC/TD NEMA	182 TC/TD	225	185	114.3	40	10	10	50	20	25	14	20	M10	
5695	MDS 184+213 TC/TD NEMA	184+213 TC/TD	254	216	139.7	45	10	10	50	20	25	14	20	M10	
4455	MDS 215 TC/TD NEMA	215 TC/TD	285	245	177.8	45	10	10	50	20	25	14	20	M10	
4392	MDS 254 TC/TD NEMA	254 TC/TD	330	295	209.5	45	10	10	50	20	25	14	20	M12	
4444	MDS 256 TC/TD NEMA	256 TC/TD	375	340	254.0	45	15	15	50	20	25	14	20	M12	
5691	MDS 284 TC/TSC/TD NEMA	284 TC/TSC/TD	406	362	241.3	60	15	15	70	30	35	18	26	M12	
5691	MDS 286 TC/TSC/TD NEMA	286 TC/TSC/TD	406	362	279.4	60	15	15	70	30	35	18	26	M12	
4452	MDS 324 TC/TSC/TD NEMA	324 TC/TSC/TD	416	370	267.0	60	15	15	70	35	35	18	26	M12	
4453	MDS 326 TC/TSC/TD NEMA	326 TC/TSC/TD	458	410	305.0	60	15	15	70	35	35	18	26	M16	
4440	MDS 364 TC/TSC/TD NEMA	364 TC/TSC/TD	446	400	285.8	60	15	15	70	30	35	18	26	M16	
5690	MDS 365 TC/TSC/TD NEMA	365 TC/TSC/TD	458	410	311.1	60	15	15	70	35	35	18	26	M16	
5689	MDS 404 TC/TSC/TD NEMA	404 TC/TSC/TD	500	445	311.1	60	15	15	100	50	50	27	40	M16	
5703	MDS 405 TC/TSC/TD NEMA	405 TC/TSC/TD	533	476	349.0	60	15	15	100	50	50	27	40	M16	
4448	MDS 444 TC/TSC/TD NEMA	444 TC/TSC/TD	580	530	368.3	60	15	15	100	50	50	25	40	M16	
5688	MDS 445 TC/TSC/TD NEMA	445 TC/TSC/TD	660	605	419.1	60	15	15	100	50	50	25	40	M16	

TYPE PTFL-DS / PTFS-DS FOR FOOT FLANGES

Art. No.	Type	Foot flange size	Dimensions [mm]												
			L	L1	L2	H	H1	H2	B	B1	B2	Ød	ØD	G	Shore° A
4498	PTFL-DS 160	PTFL 160	176	130	50	40	10	10	50	10	25	14	20	M8	55°
4483	PTFL-DS 200	PTFL 200	176	130	60	40	10	10	50	15	25	14	20	M10	
4484	PTFL-DS 250	PTFL 250	230	140	60	40	10	10	50	15	25	14	20	M12	
4485	PTFL-DS 300	PTFL 300	270	170	80	40	10	10	50	15	25	14	20	M12	
4486	PTFL-DS 350	PTFL 350	305	200	110	60	10	10	70	25	35	18	26	M16	
4490	PTFS-DS 200	PTFS 200	245	205	150	40	10	10	50	19	25	14	20	M10	55°
4491	PTFS-DS 250	PTFS 250	300	260	185	40	10	10	50	21	25	14	20	M12	
4492	PTFS-DS 300	PTFS 300	340	300	225	45	10	10	50	21	25	14	20	M12	
4493	PTFS-DS 350	PTFS 350	390	345	265	60	15	15	70	29	35	18	26	M16	
4494	PTFS-DS 400	PTFS 400	425	380	300	60	15	15	70	29	35	18	26	M16	
4495	PTFS-DS 450	PTFS 450	470	425	335	60	15	15	70	35	35	18	26	M16	
4496	PTFS-DS 550	PTFS 550	565	515	415	60	15	15	70	35	35	18	26	M16	
4497	PTFS-DS 660	PTFS 660	655	605	495	60	15	15	100	50	50	22	33	M20	

DAMPING FLANGES

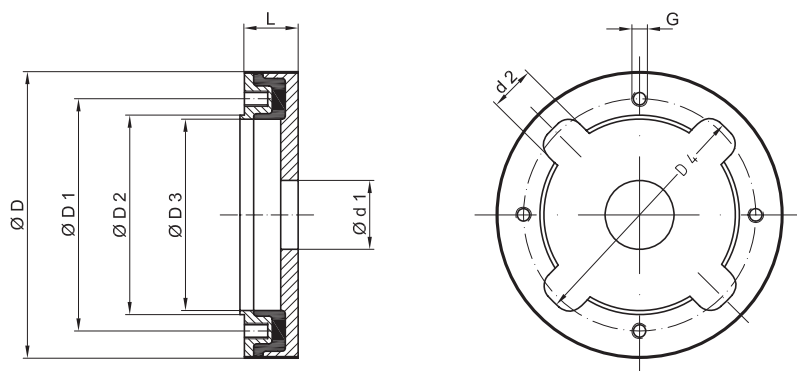

DF 200-400

Art. No.*	Type	Dimensions [mm]								
		Ø D	Ø D1	Ø D2	Ø D3	Ø D4	Ø d1 _{min}	d2	L	G
5410	DF 200/.../30/.../1	142	102	90	85	120	32	25	30	M8 x 10
5412	DF 250/16/35/.../1	186	150	130	125	156	32	28	35	M10 x 15
5415	DF 300/32/40/.../1	222	175	147	140	190	33	55	40	M12 x 16
5420	DF 350/63/45/.../1	258	195	172	165	230	48	60	45	M12 x 16
5425	DF 400/84/60/.../1	365	248	212	200	335	120	45	60	M20 x 23

* standard version "S"

RADIAL WEIGHT LOAD

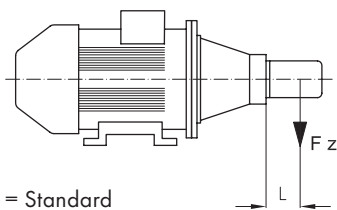

S = Standard
H = Hard

$$F_{zul.} = \frac{(F[N] \times L)}{\text{effective SPA}^{**}}$$

** Centroidal distance

*** for operating temperature up to 60°C

Damping flange	DF 200/...		DF 250/16		DF 300/32		DF 350/63		DF 400/84	
	S	H	S	H	S	H	S	H	S	H
Centroidal distance for radial load L [mm]	70		100		100		200		200	
Permittable weight load $F_{zul.}$ [N]***	300	400	1100	1300	1600	1900	1400	2000	3000	4000

DF-ZRP/1-2

Rectangular damping flange for external gear pumps of types 1 and 2 for application in connection with bellhousings or pump brackets for steady or mobile applications

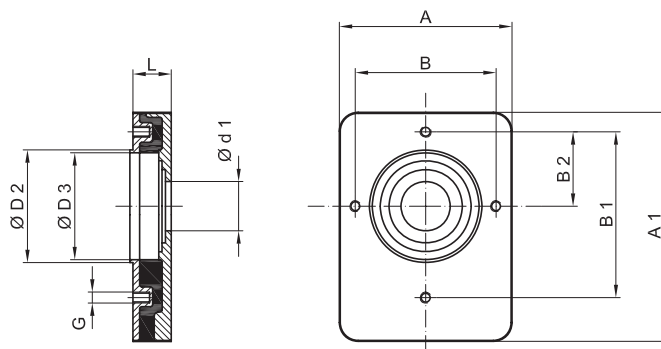

Typ	Dimensions [mm]									
	A	A1	B	B1	B2	Ø D2	Ø D3	Ø d1 _{min}	G	L
DF ZRP/1-2	92	122	75	87.5	37.5	60	57	25	M8	20

DAMPING RINGS

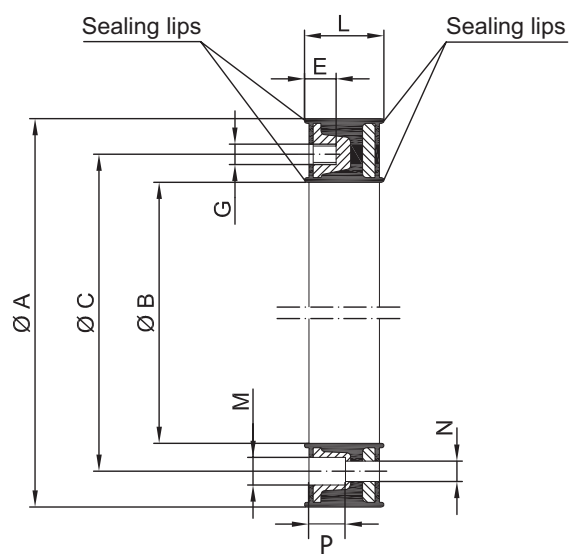

Type

DA ...

Type

DA ... / 2

4 through bores

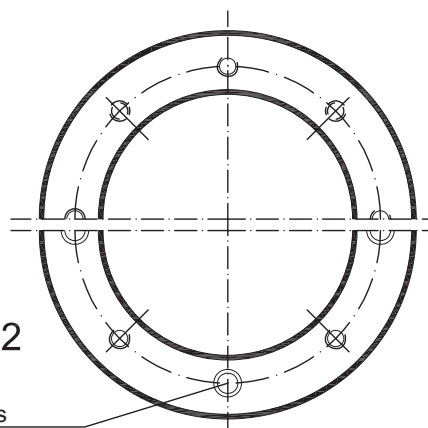

Only for vertical assembly

Art. No.	IEC motor size	Type	Dimensions [mm]								
			ø A	ø B	ø C	G	E	L	M	N	P
4324	71	DA 160	160	111	130	M8	16	38	-	-	-
4325	80/90	DA 200	200	146	165	M10	20	43	-	-	-
4326	100/112	DA 250*	250	191	215	M12	20	48	-	-	-
4327	132	DA 300*	300	235	265	M12	20	53	-	-	-
4328	160/180	DA 350*	350	261	300	M16	24	64	-	-	-
4329	200	DA 400*	400	308	350	M16	24	62	-	-	-
4330	225S/225M	DA 450*	450	352	400	M16	32	69	-	-	-
4331	250M/280S/280M	DA 550*	550	452	500	M16	32	72	-	-	-
4332	315S/315M	DA 660*	660	552	600	M20	32	72	-	-	-
4341	71	DA 160/2	160	111	130	M8	16	38	14.5	9	15
4340	80/90	DA 200/2	200	146	165	M10	20	43	16.5	11	20
4333	100/112	DA 250/2*	250	191	215	M12	26	48	18.5	14	20
4334	132	DA 300/2*	300	235	265	M12	26	53	18.5	14	20
4335	160/180	DA 350/2*	350	261	300	M16	24	64	24.5	18	20
4336	200	DA 400/2*	400	308	350	M16	24	62	24.5	18	20
4337	225S/225M	DA 450/2*	450	352	400	M16	32	69	26	18	20
4338	250M/280S/280M	DA 550/2*	550	452	500	M16	32	72	26	18	20
4339	315S/315M	DA 660/2*	660	552	600	M20	32	72	33	22	30

*incl. breakaway quick-closing device

MOUNTING FLANGES

PRODUCT DESCRIPTION

- Mounting flanges enable the assembly / disassembly of the power unit including pressure line without dismounting of the cleaning cover
- Pressure lines are led through the mounting flange
- Material: ST 37
- Suitable for bellhousings $\varnothing 160 - 400$ mm
- Gaskets made of GK (rubber cork) available as accessory

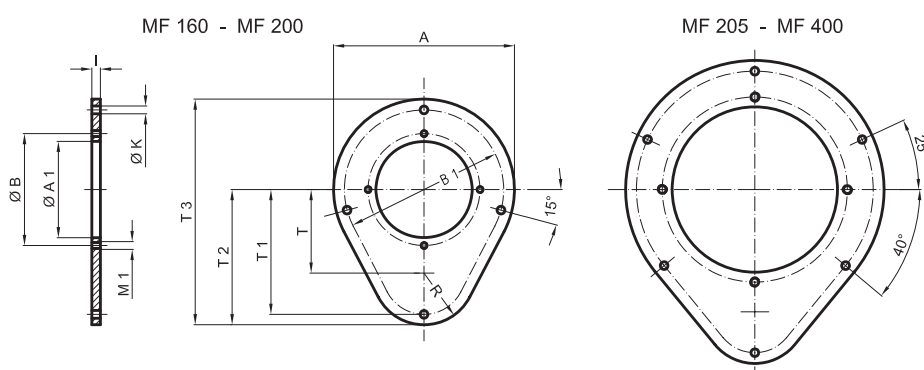

Art. No.	Type	Dimensions [mm]											Gasket between oil tank and mounting flange (2.5 mm thick)	Gasket between bellhousing and mounting flange (2.5 mm thick)	
		A	$\varnothing A1$	$\varnothing B$	B1	K	M1	R	T	T1	T2	T3			I
4499	MF 160	210	112	130	185	9	M8	60	97	145	157	262	8	DMF 160 GK	D 160 GK
4500	MF 200	250	147	165	225	9	M10	60	142	190	202	327	8	DMF 200 GK	D 200 GK
4501	MF 250	300	192	215	275	9	M12	60	142	190	202	352	8	DMF 250 GK	D 250 GK
4502	MF 300	360	236	265	330	14	M12	90	150	225	240	420	8	DMF 300 GK	D 300 GK
4503	MF 350	410	262	300	380	14	M16	110	160	255	270	475	10	DMF 350 GK	D 350 GK
4504	MF 400	480	304	350	440	18	M16	150	175	305	325	565	10	DMF 400 GK	D 400 GK

GASKET MOUNTING FLANGE

- Material: rubber cork (GK)
- DMF gaskets are applied between MF mounting flange and cleaning cover
- Available from stock

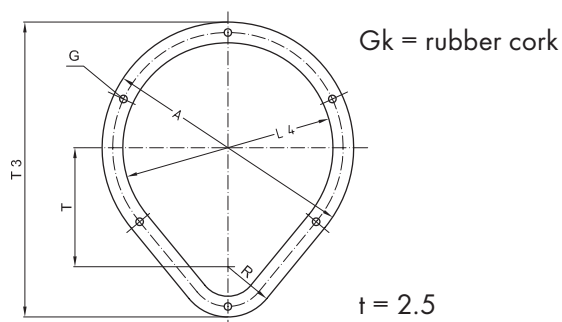

Art. No.	Type	Dimensions [mm]					
		T3	T	R	A	L4	G
4509	DMF 160 GK	262	97	60	210	160	10 (4x)
4510	DMF 200 GK	325	140	60	250	200	10 (4x)
4511	DMF 250 GK	350	140	60	300	250	10 (6x)
4512	DMF 300 GK	420	150	90	360	300	14 (6x)
4513	DMF 350 GK	475	160	110	410	350	19 (6x)
4514	DMF 400 GK	565	175	150	480	400	19 (6x)

GASKETS FOR BELLHOUSINGS AND GEAR PUMPS

PRODUCT DESCRIPTION

- D gaskets are applied between bellhousing and cleaning cover and also between bellhousing and MF mounting flange
- D gaskets made of rubber cork (GK)
- PD gaskets are applied between pump and bellhousing
- PD gaskets made of paperboard (P)
- All gaskets are available from stock

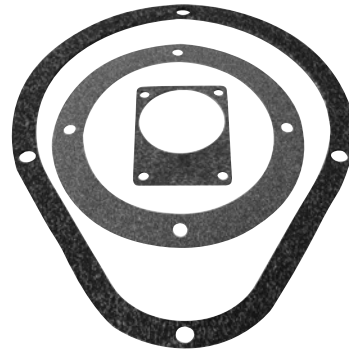

TYPE "D"

Art. No.	Type	Dimensions [mm]			
		D	D1	D2	G
4359	D 140 GK	140	115	100	10 (4x)
4360	D 160 GK	160	130	112	10 (4x)
4361	D 200 GK	200	165	147	12 (4x)
4362	D 250 GK	250	215	193	14 (4x)
4363	D 300 GK	300	265	245	14 (4x)
4364	D 350 GK	350	300	270	19 (4x)
4365	D 400 GK	400	350	303	19 (4x)
4366	D 450 GK	450	400	353	19 (8x)
4367	D 500 GK	550	500	453	19 (8x)
4368	D 660 GK	660	600	554	24 (8x)

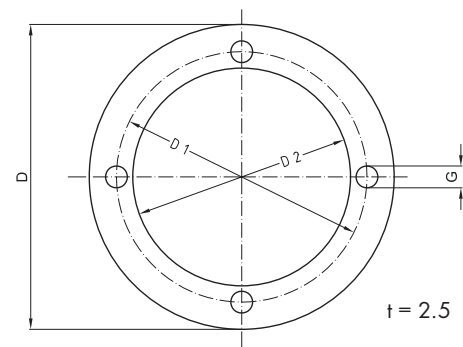

Gk = rubber cork

TYPE "PD"

Art. No.	Type	Dimensions [mm]						
		A	A1	B	B1	B2	D	G
4370	PD 0,5 P	90	69	66	-	25.5	24	7.5 (2x)
4371	PD 10 P	90	69	72	52.4	26.2	27	7.5 (4x)
4371	PD 11 P	90	69	73	56	24.5	32	7.5 (4x)
4373	PD 20 P	118	88	96	71.5	32.5	38	9.5 (4x)
4374	PD 25 P	170	120	128	98.5	43	∅ 52	9.5 (4x)
4374	PD 28 P	170	120	137	98.4	45	∅ 52	12 (4x)
4376	PD 35 P	180	158	149.5	114.3	49.5	62	12 (4x)
4377	PD 40 P	230	175	196	142.8	65	65	15 (4x)
4377	PD 45 P	230	175	188	143	64.3	65	15 (4x)
4379	PD 60 P	75	60	40	40	10.3	34	9.5 (4x)
4380	PD 70 P	121	91	100	72	34.5	82	9.5 (4x)
4381	PD 80 P	165	122	145	102	48	107	12 (4x)

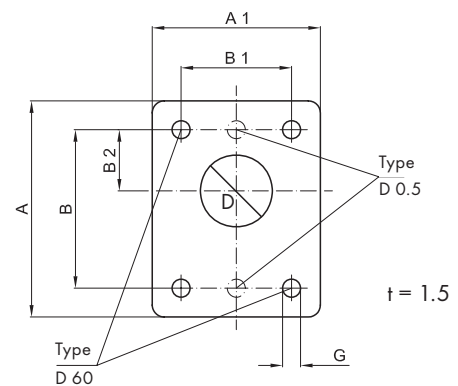

P = paperboard

BELLHOUSING WITH INTEGRATED OIL COOLER

PRODUCT DESCRIPTION

- Series PTÖK: bellhousing with oil air cooler
- Model series for electric motors 0.55 - 22 kW (IMB 5/IMB 35/IMV 1)
- Noise reduced design, form B
- Cooling capacity 0.95 - 5.15 kW
- 4 model series available (ø200 - ø350)
- All bellhousing lengths comply with VDMA 24561
- The standard bellhousing can be replaced easily with a bellhousing with oil cooler at any time due to identical installation lengths
- Horizontal - IMB 5/IMB 35 - and vertical - IMV 1 - use possible
- Foot flanges type PTFL and PTFS mountable acc. to VDMA 24561

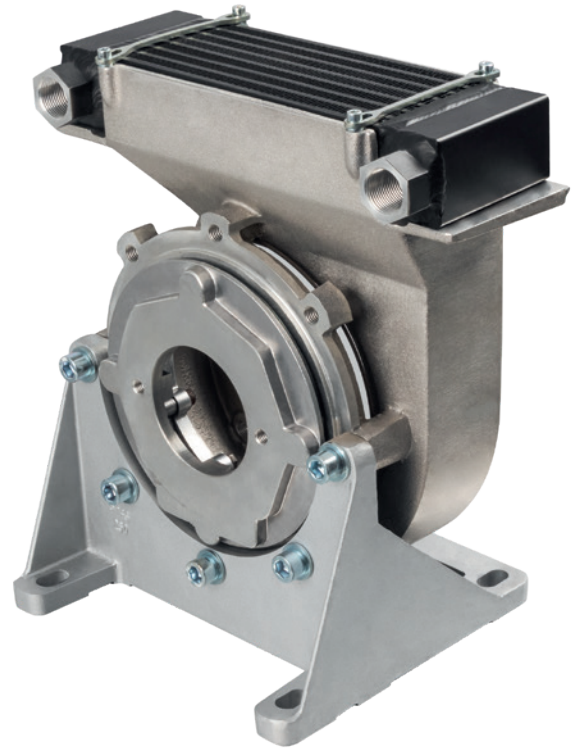

Order code							
Type	Size		Length		Ø Fan wheel		Pump face code
PTÖK	250	/	120	/	LR28	/	20

TECHNICAL ADVANTAGES

- High cooling capacity with low noise output on the smallest installation space
- Suitable as reflux or leak oil cooler
- Requires no electrical installation
- Easy to maintain due to simple installation and removal of the cooling element
- Due to standard damping, reduction of noise level up to 6 dB (A) possible

TECHNICAL DATA

Operating pressure:	16 bar
Load change:	1×10^6 , $f = 2$ Hz
Max. static pressure:	10 bar

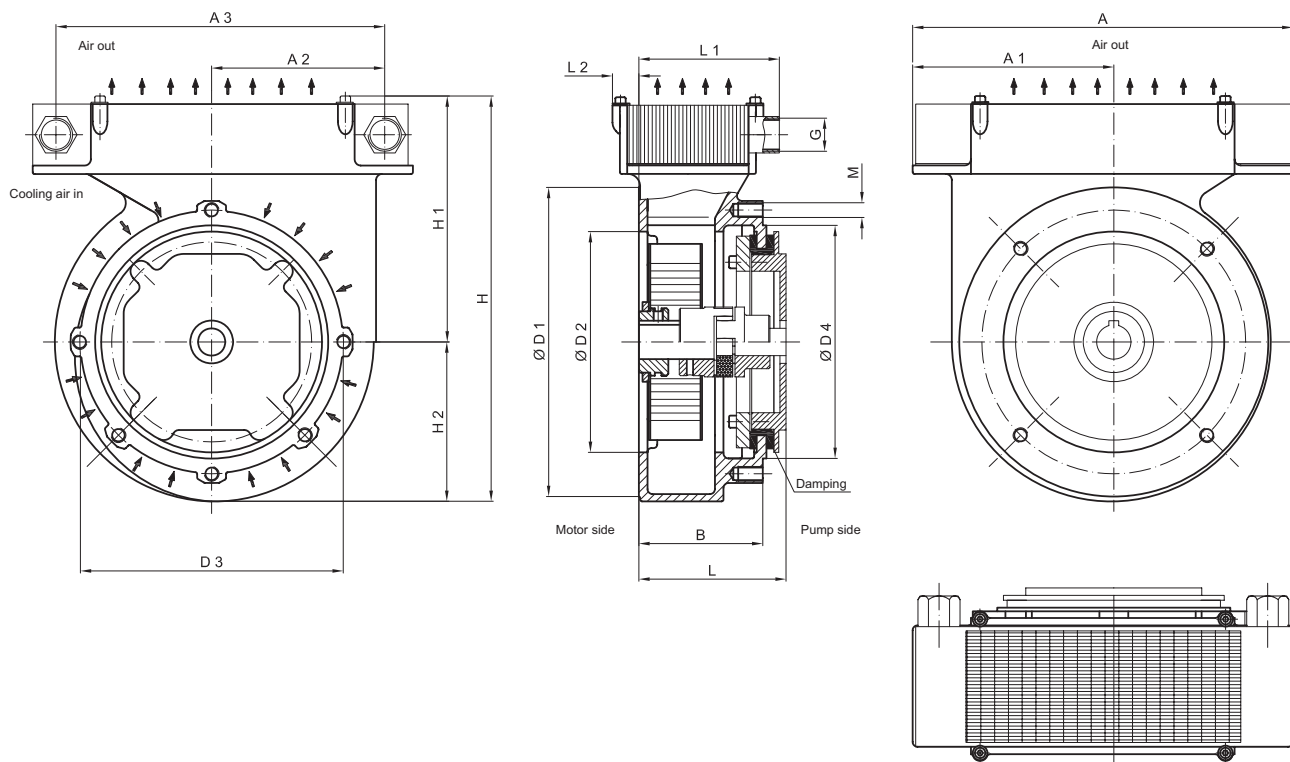

Type	E-motor size	Power [kW]	Shaft	Foot flanges type	Dimensions [mm]																	
					A	A1	A2	A3	B	ØD1	ØD2	D3	ØD4	G	H	H1	H2	L	L1	L2	M	
PTÖK 200	80	0.55	19 x 24	PTFL 200	242	139	101.5	203	70	200	130	165	145	G 1/2	285	180	100	100	88	10,3	M10	
		0.75																110				
	90 S + L	1.1	24 x 50															124				
		1.5																140				
PTÖK 250	100 L	2.2	28 x 60	PTFL 250 PTFS 250	310	164	144.5	267	102	252	180	215	190	G 3/4	329	199	130	120	101.5	22	M12	
		3.0																124				
	112 M	4																128				
																		135				
																		148				
PTÖK 300	132 S + M	5.5	38 x 80	PTFL 300 PTFS 300	310	191	168.5	267	126	300	230	265	234	G 3/4	384	234	150	144	128.5	8	M12	
		7.5																150				
		168																				
		196																				
		188																				
PTÖK 350	160 M + L	11	42 x 110	PTFL 350 PTFS 350	355	230	210.5	316	152	350	250	300	260	G 3/4	426	251	175	204	155	6	M16	
		15																228				
	180 M + L	18.5																22				228
																						256

BELLOUSING WITH INTEGRATED OIL COOLER

COOLING CAPACITY

Type	Cooling capacity ⁽¹⁾ P [kW] $\Delta t = 40 \text{ K}$	Power E-motor ⁽³⁾ [kW]	Air flow [m ³ / h]	Input power [W]	Noise level ⁽²⁾ [dB (A)]	Correlation cooling and motor power %
PTÖK 200	0.95	0.55 - 1.5	72	20	52	63 - 100
PTÖK 250	2.1	2.2 - 4	260	30	58	53 - 95
PTÖK 300	3.22	5.5 - 7.5	430	90	69	43 - 59
PTÖK 350	5.15	11 - 22	780	140	70	23 - 46

⁽¹⁾ The indicated capacity relates to the nominal rotation for the driven machine and is $1,500 \text{ min}^{-1}$. In case of different speeds, please contact HBE.

⁽²⁾ Noise levels of damped version with bellhousing and electric motor are measured with 1 m distance to the tested objects. The stated values of noise level will be various depending on the electric motor.

⁽³⁾ Direction of pump rotation always clockwise (looking on pump shaft)

Should no additional heat sources have an effect on the hydraulic aggregate between 30 and 40 percent of the engine output is lost as heat energy when the engine is operated at an average efficiency. A part of this heat is released outwards from the individual components. Above all, the surface area of the tank plays an important role here. However, some heat energy remains which may lead to overheating of the oil. In order to avoid this, the usage of an additional cooler is required. In the vast majority of cases, a cooling capacity of between 20 to 30 percent of the engine output is sufficient – also with aggregates with a smaller tank surface area.

Meanwhile, it is hard to imagine oil hydraulics without bellhousing coolers. They are simple to install, they require very little space – particularly due to the ventilation system no longer being required – and, in most applications, achieve the complete required cooling capacity. See figure 1.

The values from figure 1 apply for an optimal amount of oil flow and applies to one Δt from 40 K. Should the oil flow be notably low or not sufficiently continual, the installation of a separate cooling circuit could be necessary – even this is effortlessly convertible with PTÖK bellhousing coolers. Figure 1 shows the dependency of the cooling capacity with the amount of oil flow. You will achieve the actual cooling capacity by multiplying the values for 1K Δt with the relevant Δt .

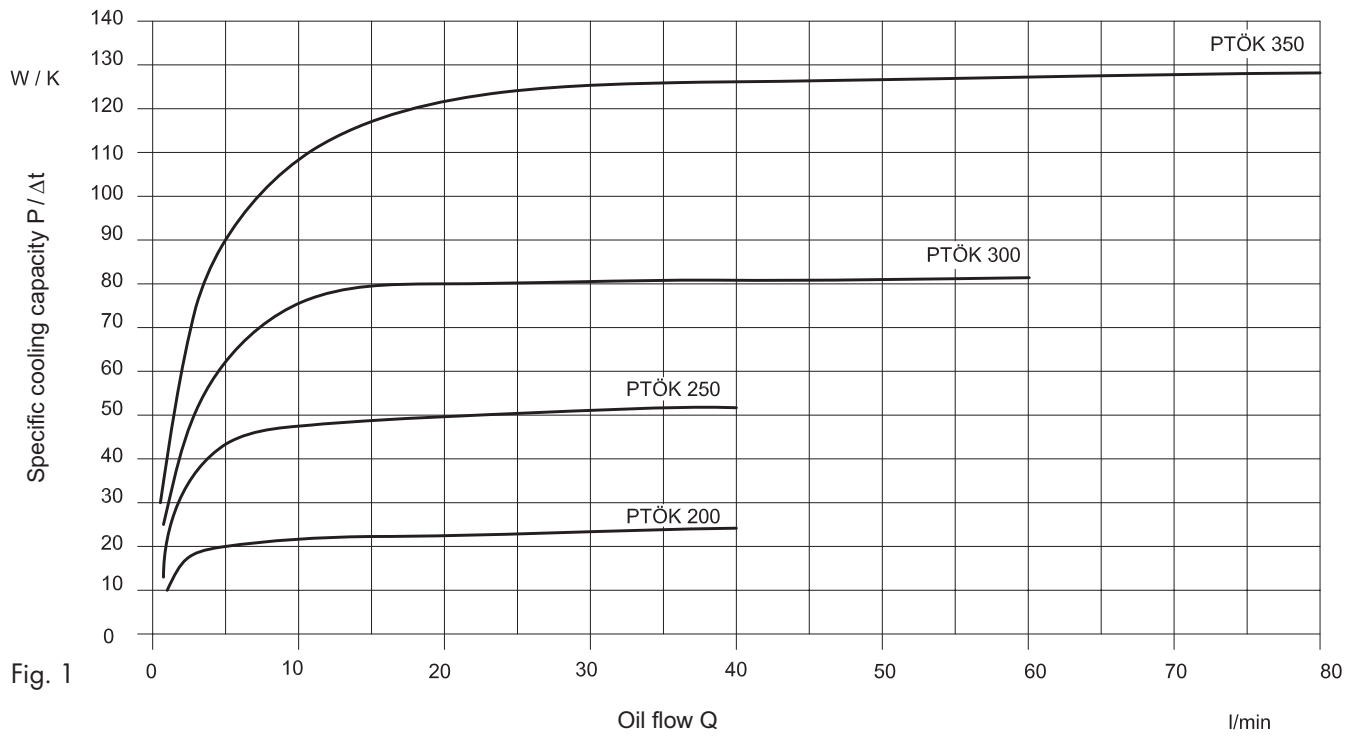

Fig. 1

Specific cooling capacity $P / \Delta t$ depending on oil flow Q and temperature difference $\Delta t = 1 \text{ K}$ (oil inlet to air inlet).

Online catalogue



epaper.hbe-hydraulics.com/en

HBE hydraulic
components

HBE GmbH
Hönnestraße 47
58809 Neuenrade /Germany

Phone +49 (0) 23 94 / 616-0
Fax +49 (0) 23 94 / 616-25
info@hbe-hydraulics.com
www.hbe-hydraulics.com



e.holding
FLUID TECHNOLOGY GROUP
www.e-holding.de

distributed by