

Return Filters - Lightline
RFT 103 · RFT 143

Tank top mounting · Connection G1 / -16 SAE · Nominal flow rate up to 175 l/min / 46 gpm

M

Return Filter RFT 103

Description
Application

In the return line circuits of hydraulic systems.

Performance features
Protection against wear:

By means of filter elements that even in full-flow filtration meet the highest demands regarding cleanliness classes.

Protection against malfunction:

By means of full-flow filtration in the system return, the pumps above all are protected from dirt particles remaining in the system after assembly, repairs, or which are generated by wear or enter the system from outside.

Special features

- › Bypass valve:
The location close to the inlet port prevents dirt particles retained by the filter element from entering into the clean oil side.
- › Removable bowl:
In case of maintenance the filter bowl is removed together with the filter element – therefore dirt particles are not flushed back into the tank.
- › Extension pipe:
A correct extension pipe length ensures oil outlet below minimum oil level and prevents foaming.

Filter elements

Flow direction from outside to center.

The star-shaped pleating of the filter material results in:

- › large filter surfaces
- › low pressure drop
- › high dirt-holding capacities
- › long service life

Ventilating filter

Ventilation of the reservoir by an integral star-shape pleated filter element:

- › removable (replace annually!)
- › splash-proof
- › fineness 2 µm

Filter maintenance

By using a clogging indicator the correct moment for maintenance is stated and thus the optimum utilization of the filter life is guaranteed.

Materials

| | |
|---------------|---|
| Screw-on cap: | Polyester, GF-reinforced |
| Filter head: | Aluminum alloy |
| Filter bowl: | Polyamide, CF-reinforced |
| Seals: | NBR (FPM on request) |
| Filter media: | EXAPOR®Light - inorganic multi-layer microfiber web Paper - cellulose web, impregnated with resin |

Accessories

Electrical and optical clogging indicators are available on request.
For technical data and dimensions see datasheet 60.20.

An optional oil separator (Part No. E 103.1702) is available on request.

Extension pipes on the bowl outlet are available in several lengths on request.

Characteristics

Nominal flow rate

Up to 175 l/min / 46 gpm.

The nominal flow rates indicated by ARGO-HYTOS lightline are based on the following features:

- › closed by-pass valve at $v \leq 150 \text{ mm}^2/\text{s}$ / 698 SUS
- › element service life > 500 operating hours at an average fluid contamination of 0.07 g per l/min / 0.27 g per gpm flow volume
- › flow velocity in the connection lines $\leq 6 \text{ m/s}$ / $\leq 20 \text{ ft/s}$

Connection

Threaded ports according to

- › ISO 228 or DIN 13 and
- › SAE standard J514

Sizes see Selection Chart, page 3
(other port threads on request).

Filter fineness

10 $\mu\text{m(c)}$... 30 $\mu\text{m(c)}$

β -values according to ISO 16889 (see diagrams).

Hydraulic fluids

Mineral oil and biodegradable fluids
(HEES and HETG, see info-sheet 00.20).

Temperature range

-30 °C ... +100 °C (temporary -40 °C ... +120 °C)
-22 °F ... +212 °F (temporary -40 °F ... +248 °F)

Viscosity at nominal flow rate

- › at operating temperature: $v < 60 \text{ mm}^2/\text{s}$ / 280 SUS
- › as starting viscosity: $v_{\text{max}} = 1200 \text{ mm}^2/\text{s}$ / 5560 SUS

Operating pressure

Max. 10 bar / 145 psi

Mounting position

Preferably vertical, outlet downwards.

Dimensions

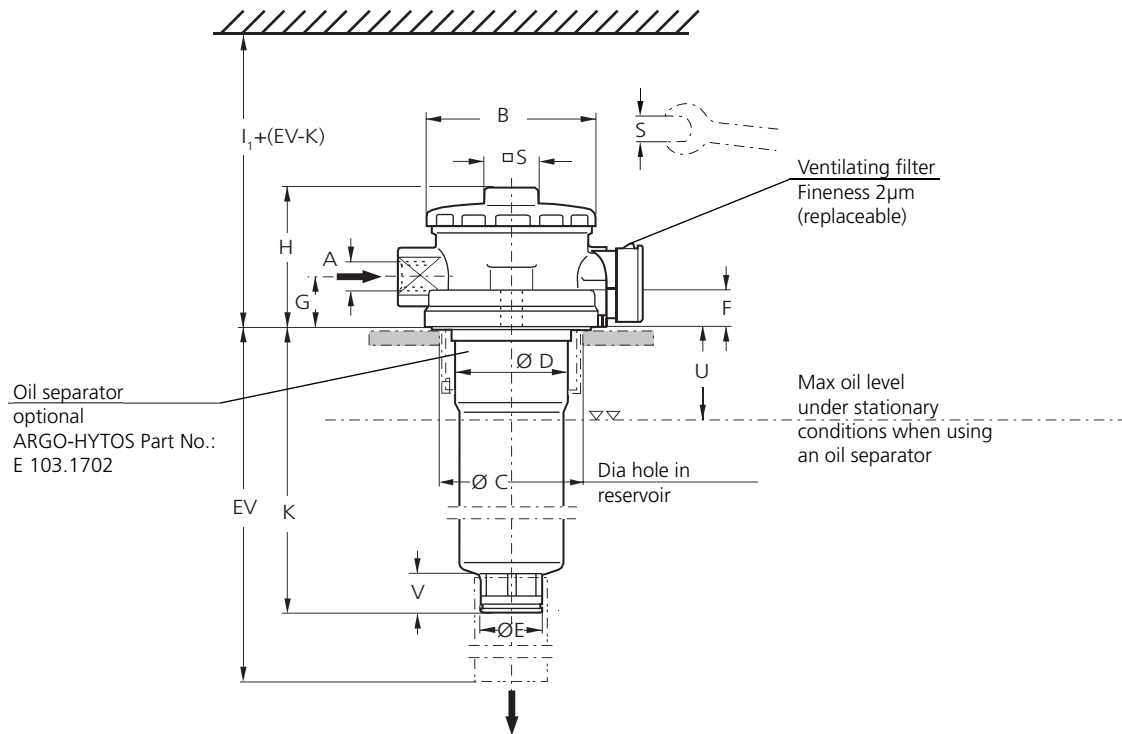

Design without ventilating filter

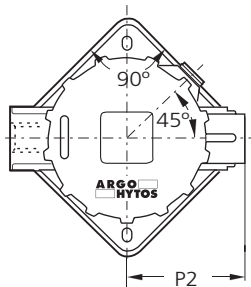

Design with ventilating filter

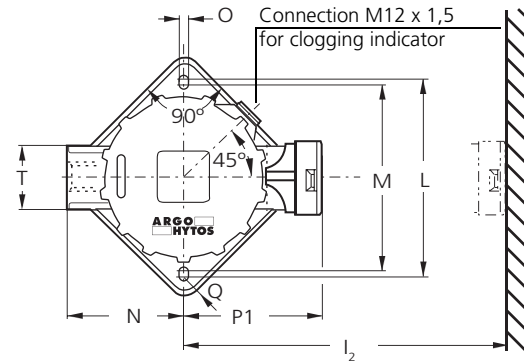

Required mounting surface

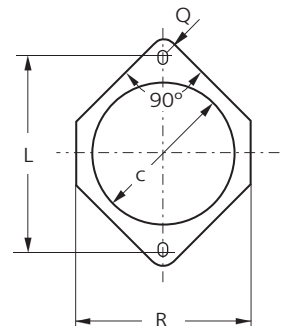

Measurements in mm

| Type [mm] | A | B | C min/max | D | E | F | G | H | I ₁ | I ₂ | K | L | M | N |
|-----------|----------|-----|-----------|------|----|------|----|------|----------------|----------------|-----|-----|-----|----|
| RFT 103 | G1 or | 105 | 87/91 | 73.5 | 38 | 20.5 | 30 | 88.5 | 300 | 125 | 177 | 115 | 110 | 70 |
| RFT 143 | -16 SAE* | 105 | 87/91 | 73.5 | 38 | 20.5 | 30 | 88.5 | 400 | 125 | 278 | 115 | 110 | 70 |

| Type [mm] | O | P ₁ | P ₂ | Q | R | S | T | U | V |
|-----------|----|----------------|----------------|------|-------|-------|-------|----|----|
| RFT 103 | 11 | 82 | 69 | 13.5 | 107.5 | AF 32 | AF 41 | 50 | 23 |
| RFT 143 | 11 | 82 | 69 | 13.5 | 107.5 | AF 32 | AF 41 | 50 | 23 |

* Corresponds to 1⁵/₁₆-12 UN-2B

Measurements in inch

| Type [inch] | A | B | C min/max | D | E | F | G | H | I ₁ | I ₂ | K | L | M | N |
|-------------|----------|------|-------------|-----|-----|------|------|------|----------------|----------------|-------|------|------|------|
| RFT 103 | G1 or | 4.13 | 3.43 / 3.58 | 2.9 | 1.5 | 0.81 | 1.18 | 3.48 | 11.81 | 4.92 | 6.97 | 4.53 | 4.33 | 2.76 |
| RFT 143 | -16 SAE* | 4.13 | 3.43 / 3.58 | 2.9 | 1.5 | 0.81 | 1.18 | 3.48 | 15.75 | 4.92 | 10.94 | 4.53 | 4.33 | 2.76 |

| Type [inch] | O | P ₁ | P ₂ | Q | R | S mm | T mm | U | V | | | | | |
|-------------|------|----------------|----------------|------|------|-------|-------|------|------|--|--|--|--|--|
| RFT 103 | 0.43 | 3.23 | 2.72 | 0.53 | 4.23 | AF 32 | AF 41 | 1.97 | 0.91 | | | | | |
| RFT 143 | 0.43 | 3.23 | 2.72 | 0.53 | 4.23 | AF 32 | AF 41 | 1.97 | 0.91 | | | | | |

*Corresponds to 1 5/16 - 12 UN - 2B

Symbols

Without air breather

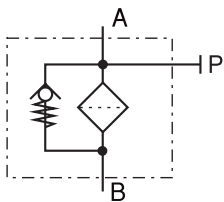

With air breather

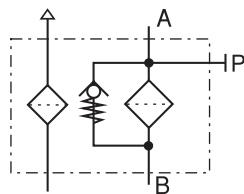

Ordering Code

Filter assembly

Order example:

RFT - 103 - GD - N3 - KM - 101

| Type of filter | Code |
|-----------------------------|------|
| Return Filter, tank mounted | RFT |

| Flow rate, max. | Code |
|--------------------|------|
| 125 l/min / 33 gpm | 103 |
| 175 l/min / 46 gpm | 143 |

| Connection thread | Code |
|-------------------|------|
| G1 | GD |
| -16 SAE | UD |

| Filter fineness | Code |
|-----------------|------|
| 10 µm (10EL) | G2 |
| 16 µm (16EL) | I2 |
| 30 µm (30P) | N3 |

| Air breather | Code |
|----------------------|------|
| Without air breather | 100 |
| With air breather | 101 |

| Bypass setting | Code |
|-----------------------------------|------|
| 2.5 bar / 36 psi (for 10EL, 16EL) | OM |
| 1.5 bar / 22 psi (for 30P) | KM |

Filters delivered with plugged connection M12 x 1.5 for clogging indicator.

Spare filter element

Order example:

P3.0620-51

| Filter media | Code |
|--------------|------|
| EXAPOR®Light | F |
| Paper | P |

| Length | Code |
|-------------|------|
| for RFT 103 | 620 |
| for RFT 143 | 730 |

| Filter fineness | Code |
|-----------------|------|
| 10EL | 6 |
| 16EL | 8 |
| 30P | 1 |

Spare parts

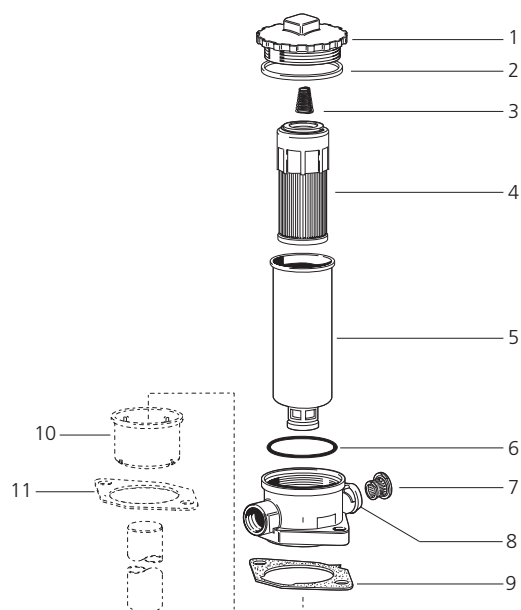

| Pos. | Designation | Part No. |
|------|---|--------------|
| 1 | Screw-on cap | E 103.0201 |
| 2 | Flat Gasket | N031.0841 |
| 3 | Compression spring | N015.3703 |
| 4 | Replacement filter element | see above |
| 5 | Filter bowl RFT 103 | E 103.0912 |
| 5 | Filter bowl RFT 143 | E 143.0903 |
| 6 | O-ring 69.5 x 3.5 mm / 2.74 x 0.14 inch | N007.0703 |
| 7 | Replacement air breather | L1.0503-03K |
| 8 | Housing (for Pos. 7) | L1.0503.0801 |
| 9 | Flat gasket (for versions without breather / oil separator) | E 103.0147 |
| 10 | Oil separator | E 103.1702 |
| 11 | Flat gasket (for versions with breather / oil separator) | E 103.0148 |

The functions of the complete filters as well as the outstanding features of the filter elements assured by ARGO-HYTOS can only be guaranteed if original ARGO-HYTOS spare parts are used.

Δp-curves for complete filters

D1 Pressure drop as a function of the **flow volume** at $v = 35 \text{ mm}^2/\text{s} / 162 \text{ SUS}$ (0 = housing empty)

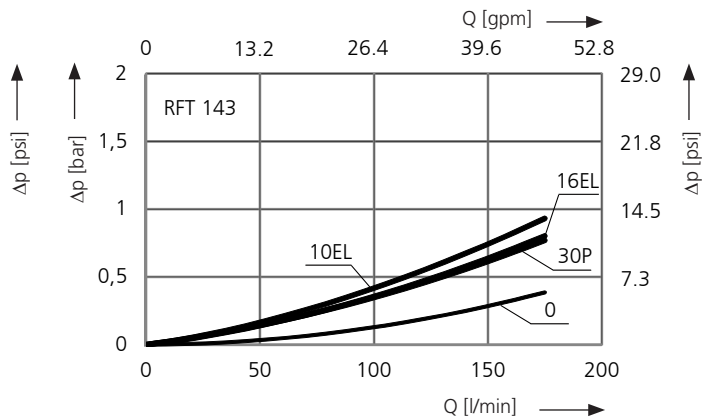
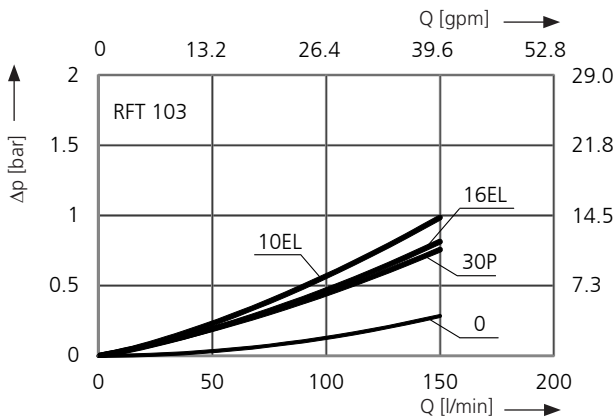

Filter fineness curves

Dx Filtration ratio β as a function of particle size x obtained by the Multi-Pass-Test according to ISO 16889

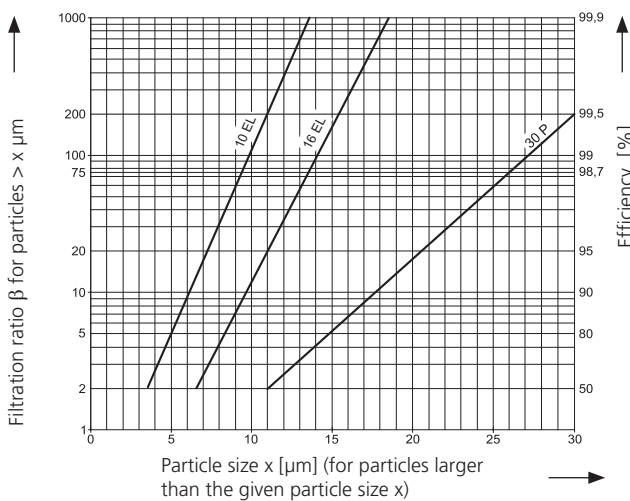

The abbreviations represent the following β -values resp. finenesses:

For EXAPOR®Light and Paper elements:

- 10 EL = $\bar{\beta}_{10(c)} = 200$ EXAPOR®Light
- 16 EL = $\bar{\beta}_{16(c)} = 200$ EXAPOR®Light
- 30 P = $\bar{\beta}_{30(c)} = 200$ Paper

Based on the structure of the filter media of the 30P paper elements, deviations from the printed curves are quite probable.

For ventilating filter elements:

- 2 CL = 99.5% efficiency for particles of size 2 μm

For special applications, finenesses differing from these curves are also available by using special composed filter material.

Quality Assurance

Quality management according to DIN EN ISO 9001

To ensure constant quality in production and operation, ARGO-HYTOS filter elements undergo strict controls and tests according to the following ISO standards:

- ISO 2941 Verification of collapse / burst pressure rating
- ISO 2942 Verification of fabrication integrity (Bubble Point Test)
- ISO 2943 Verification of material compatibility with fluids
- ISO 3968 Evaluation of pressure drop versus flow characteristics
- ISO 16889 Multi-Pass-Test (evaluation of filter fineness and dirt-holding capacity)
- ISO 23181 Determination of resistance to flow fatigue using high viscosity fluid

Various quality controls during the production process guarantee the leakfree function and solidity of our filters.

Illustrations may sometimes differ from the original. ARGO-HYTOS is not responsible for any unintentional mistake in this specification sheet.